

AEG

Premier Partner

INNOVATIVE, CONNECTED, RESPONSIVE.

Kitchen and Laundry range



IN THE PERFECT HOME, YOU'RE IN COMPLETE CONTROL

Welcome to AEG's kitchen and laundry range. Inside every appliance, you'll find intelligent technology and responsive design, guaranteeing you exceptional performance and results time after time. You'll discover that one touch redefines what's possible at home.

We innovate so that you can elevate what you do to new heights every day.

INTRODUCTION		HOODS	106
Pioneers with a vision.	02	DISHWASHERS	118
Flavour Conducted your way.	04	Fully Integrated Dishwashers	125
Products of the Year.	06	Semi-Integrated Dishwashers	129
		Slimline Built-In Dishwashers	129
REFRIGERATION	08	LAUNDRY	130
Integrated Fridge Freezers	15	Washing Machines	134
Integrated Fridges and Freezers	22	Tumble Dryers	142
Side by Sides	29	Washer Dryers	146
Wine Cooling	30	SPECIFICATION TABLES	150
OVENS	34	INSTALLATION DIAGRAMS	194
Single Ovens	42	WARRANTIES	215
Built-In Double Ovens	49	ENERGY INFORMATION	216
Built Under Double Ovens	50		
Compacts	52		
Blackline Range	66		
HOBS	72		
Induction	80		
ComboHobs	90		
Ceramic	91		
Gas Hobs	92		
Mixed Fuel Hobs	102		
CrystalLine	103		

WE ARE PIONEERS WITH A VISION

We thrive upon innovation designed to give you the ultimate feeling of mastery in your home and laundry care. We see your needs of today. And foresee the ones of tomorrow. So that you can achieve results that don't just meet your standards, but exceed them.

We believe in intelligent technology and exceptional performance, helping you to take anything you do at home to the next level, every day.

We are proud of our distinctive engineering and responsive design, guaranteeing you the performance you expect and deserve.

We are a brand that people turn to for intelligent and exciting new ways to guarantee their outcome.

This has been our passion for over 125 years, and continues to be our passion today.

We are AEG. And together with you, we are always an idea ahead.



Lifts gentle to a new level

The world's first ComfortLift® dishwasher means less bending down, to make your life more comfortable.



AEG FSK93800P ComfortLift Dishwasher awarded Which? Best Buy status July 2017.

FLAVOUR CONDUCTED YOUR WAY.

The new Mastery Range from AEG works with you in unique ways to take your cooking to the next level. Every appliance ready to play their part, working in harmony and instantly responding to your second-by-second commands.

Now, for the first time, you can even tell the oven how you want your dish cooked – using just the words you would in a restaurant – rare, medium, well done. Or play with a hob where the entire surface follows every pan you move, no matter how big or small. It's time to expect more from the way you cook. Step into the world's most responsive cooking experience.

Maestro, your kitchen is waiting.





CUSTOMFLEX®



SENSECOOK



MAXISENSE®

INTRODUCING YOUR PRODUCTS OF THE YEAR

We are delighted to have won two awards for our AEG products in the largest UK consumer survey of its kind.

Product of the Year is the world's largest consumer-voted award for product innovation, aiming to guide consumers to the best products in the market and to reward manufacturers for quality and innovation. In the UK, the Product of the Year seal is determined by more than 10,000 consumers, who vote on product appeal, innovation and satisfaction overall.

Two of our leading appliances, the AEG SteamPro Multifunction Sous Vide Oven and the AEG 9000 Series Washing Machine range now have this accolade for 2018. And we want all of our consumers to know about it.

www.productoftheyear.co.uk





BSK892330M

STEAMPRO MULTIFUNCTION SOUS VIDE OVEN

Winner Kitchen Appliance Category.
Survey of 10,637 people by TNS.



9000 SERIES

WASHING MACHINES

Our 9000 Series includes:
L9FEC946R.

Winner Household Appliance Category.
Survey of 10,637 people by TNS.

* BSK892330M: Winner Kitchen Appliance Category. Survey of 10,637 people by TNS.

9000 Series washing machines: Winner Household Appliance Category. Survey of 10,637 people by TNS.

REFRIGERATION

Flavour is all about freshness and storing ingredients – the right humidity and temperature is vital. But how do you want your fridge arranged?

Our solution lets you decide. Everything and anything fits in perfectly for long-lasting flavour, while maintaining energy efficiency, protecting your environment and your budget.

Our Zero Degree compartments make it possible to create different chilling conditions in each part of your refrigerator. Adjust each drawer's temperature at a touch.

IN THIS SECTION

Integrated Fridge Freezers	15–21
Integrated Fridges and Freezers	22–28
Side by Sides	29
Wine cooling	30–33



ENERGY EFFICIENT



CUSTOMFLEX®



TWINTech®



ADAPTABLE FOR EVERY TASTE



CustomFlex®

Create your own perfectly organised fridge with the CustomFlex® storage system. This unique and practical inner door system allows you to arrange shelves, clips and compartments in all shapes and sizes in hundreds of different layouts, so there's always one that works best for you at any time.





LED Touch Display

Touch controls with new white LED digital display.



High Efficiency LED Lighting

High efficiency LED lighting ensures a good spread of light shines downwards in the fridge. An intelligent fan function prevents warm areas in the upper part of the fridge and creates an even temperature in all fridge levels.



Self-Closing Door

An elegant solution, with no risk of slamming. Automatically closes from an opening angle of 25–30 degrees.

PRECISION CHILLING



TwinTech®

Unlike conventional fridge freezers that use cold, ultra-dry air from the freezer and recirculate it to cool the fridge, TwinTech® Plus units have two separate cooling systems. This provides the ideal humidity in each compartment, preventing food from drying out in the fridge and delivering frost-free storage in the freezer.



Energy efficient

Did you know that our appliances are leaders in energy performances, with the highest ratings of up to A+++ -20% energy saving?

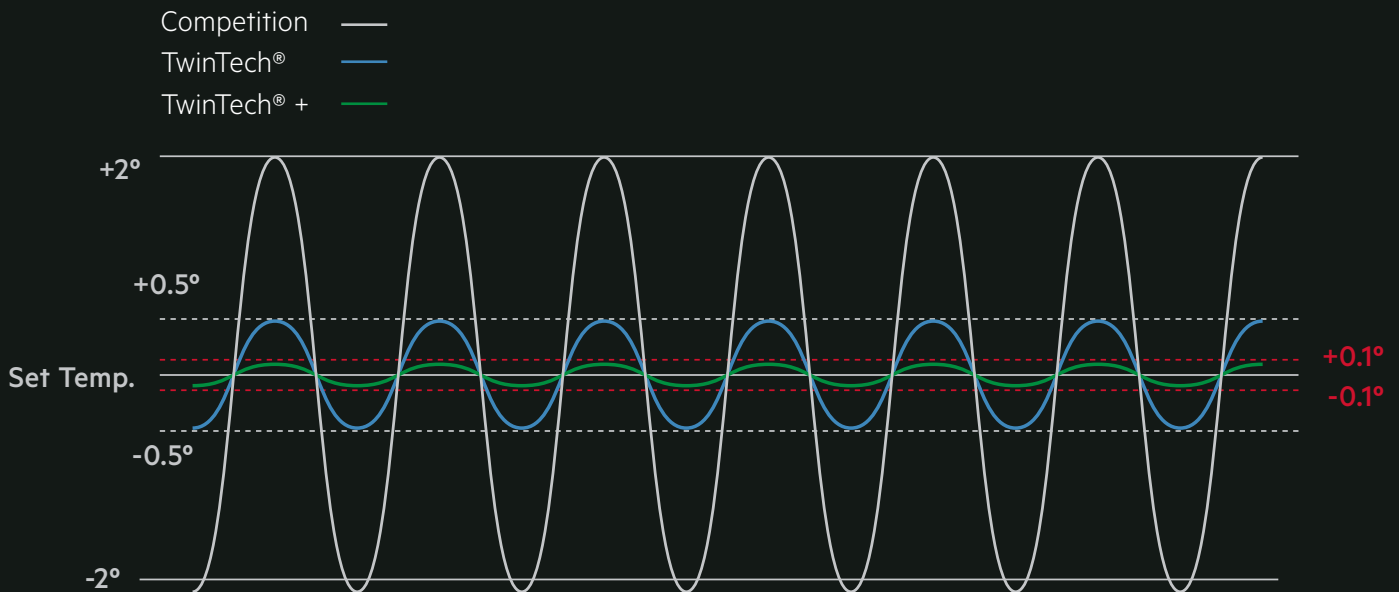



DynamicAir

DynamicAir technology maintains the airflow inside the fridge, ensuring consistent temperature at every shelf so that your ingredients stay fresh.



LowFrost/NoFrost

Never defrost your freezer again. NoFrost freezers also offer efficient and effective freezing with quicker, more even freezing for better food preservation.

Without Zero Degree

With Zero Degree



Zero Degree

Our Zero Degree compartments make it possible to create different chilling conditions in each part of your refrigerator. Adjust each drawer's temperature at a touch.

A GUIDE TO REFRIGERATION ICONS

KEY FEATURES



TwinTech®

With the pioneering TwinTech® technology for exceptional freshness. One cooling system chills the freezer, keeping it NoFrost. The other cools the fridge, ensuring that the fridge temperature is cold, stable and with the correct level of humidity.



Frostmatic

Ideal for freezing fresh food quickly, preserving the flavour, colour, texture and nutritional value.



Multi Air Flow

The Multi air flow technology provides the precise temperature and humidity your ingredients need to stay fresh throughout your fridge, nutritious and full of flavour for even longer.



CustomFlex®

Keeping all your fresh ingredients to hand is key to creating fresh, delicious dishes. Now the CustomFlex® refrigerator from AEG lets you organise your fridge storage just the way you want.



LCD Touch Display

Sleek touch controls that are intuitive and ready to use.



Ice & Water

Dispenser through the door for water and ice cubes.



NoFrost

Never defrost your freezer again. NoFrost freezers offer efficient and effective freezing with quicker, more even freezing for better food preservation.



LowFrost

Faster, more efficient defrosting. Time is of the essence when defrosting your freezer. This fridge-freezer comes with efficient LowFrost technology, which makes the defrosting faster and less frequent than ever before.



LongFresh

The LongFresh feature is a Zero Degree compartment with adjustable temperature settings and separate humidity. The two Zero Degree compartments in the AEG refrigerator allow you to choose and adjust the humidity and temperature settings in each drawer.



Touch Control

Intuitive touch controls provide instant feedback, are easy to use and look sleek in the kitchen.



Soft Close Doors

Soft Close door hinges that automatically close from an angle of 23–30 degrees – providing an elegant solution to slamming doors.



Temperature Alarm

Highlights an increase in the temperature in the freezer compartment.



Coolmatic

Ideal for chilling fresh food quickly and regaining a stable temperature within the fridge once the door has been opened, maintaining food freshness.



DynamicAir

DynamicAir technology maintains the airflow inside the fridge, ensuring consistent temperature at every shelf so that your ingredients stay fresh.



Simple Touch Controls

Our simple to use electronic controls, with Frostmatic function, ensures that you can set the fridge freezer to your desired temperature.



LED Lighting

Premium and modern lighting system in the fridge thanks to the bright LED light with rise-on effect.

REFRIGERATION

CustomFlex® a unique storage system that allows you to organise your fridge just the way you want. Move and rearrange compartments quickly and easily to maximise storage space.

CUSTOMFLEX® FRIDGE FREEZERS



CustomFlex® Integrated NoFrost Fridge Freezer
SCE8186VTC

KEY FEATURES

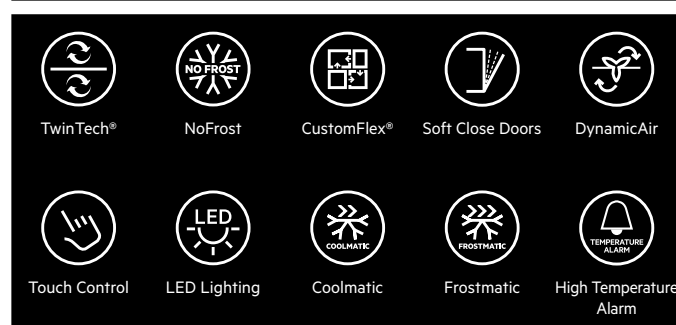

FRIDGE FEATURES

Auto defrost
3 full width + flexi shelf
2 half width salad drawers
Dairy compartment with lid
1 half width sliding door shelf
Egg tray: 2 for 6 eggs

FREEZER FEATURES

Auto defrost
3 full width drawers

DOOR FEATURES

Door open alarm
Right & reversible opening

CustomFlex®

Enables you to move and rearrange compartments quickly and easily to maximise storage space.

ADAPTABLE FOR EVERY TASTE

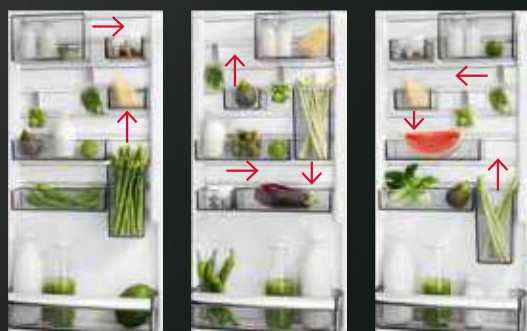

Capacity

Fridge:
189 ltr (gross)
186 ltr (net)

Freezer:
76 ltr (gross)
61 ltr (net)

Combined:
265 ltr (gross)
247 ltr (net)

Energy Rating: A+++

Additional Information

Annual energy consumption: 120kw
Noise: 39dB
Power cut safe rising time: 23
Holiday mode: Yes
Door fixing: BI DoD

Colour

White

Appliance Dimensions (HxWxD) in mm:

Combined: 1769 x 556 x 549
Built-in: 1780 x 560 x 550

REFRIGERATION

CUSTOMFLEX® FRIDGE FREEZERS



CustomFlex® Integrated NoFrost Fridge Freezer
SCE8182VNC

KEY FEATURES

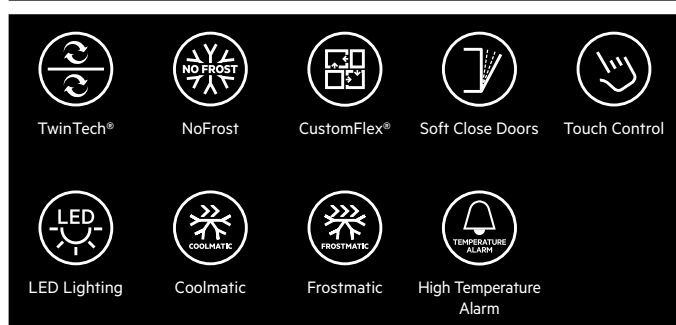

FRIDGE FEATURES

Auto defrost
3 full width + flexi shelf
2 half width salad drawers
Dairy compartment with lid
Egg tray: 2 for 6 eggs

FREEZER FEATURES

Auto defrost
3 full width drawers
DOOR FEATURES
Door open alarm
Right & reversible opening

Capacity

Fridge:
189 ltr (gross)
186 ltr (net)

Freezer:
76 ltr (gross)
61 ltr (net)

Combined:
265 ltr (gross)
247 ltr (net)

Energy Rating: A+++

Additional Information

Annual energy consumption: 226kw
Noise: 39dB
Power cut safe rising time: 23
Holiday mode: Yes
Door fixing: BI DoD

Colour

White

Appliance Dimensions (HxWxD) in mm:

Combined: 1769 x 556 x 549
Built-in: 1780 x 560 x 550



CustomFlex® Integrated NoFrost Fridge Freezer
SCE8182VTS

KEY FEATURES

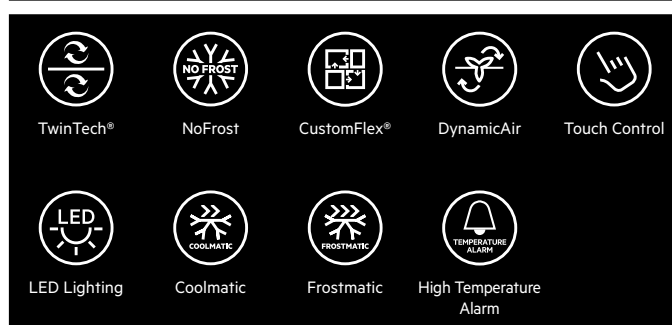

FRIDGE FEATURES

Auto defrost
3 full width + flexi shelf
2 half width salad drawers
Dairy compartment with lid
Egg tray: 2 for 6 eggs

FREEZER FEATURES

Auto defrost
3 full width drawers
DOOR FEATURES
Door open alarm
Right & reversible opening

Capacity

Fridge:
197 ltr (gross)
192 ltr (net)

Freezer:
76 ltr (gross)
61 ltr (net)

Combined:
273 ltr (gross)
253 ltr (net)

Energy Rating: A++

Additional Information

Annual energy consumption: 228kw
Noise: 39dB
Power cut safe rising time: 21
Holiday mode: Yes
Door fixing: BI slide door

Colour

White

Appliance Dimensions (HxWxD) in mm:

Combined: 1772 x 540 x 549
Built-in: 1780 x 560 x 550

EXTRA TALL FRIDGE FREEZERS



Extra Tall Integrated NoFrost Fridge Freezer
SCE8192VTS

KEY FEATURES

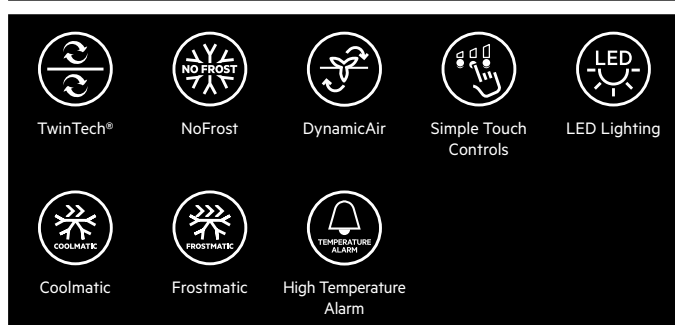

FRIDGE FEATURES

Auto defrost
3 full width + flexi shelf
Fresh box
Dairy compartment with lid
1 half width sliding door shelf
Egg tray: 2 for 6 eggs

Capacity

Fridge:
223 ltr (gross)
219 ltr (net)

Freezer:
73 ltr (gross)
64 ltr (net)

Combined:
296 ltr (gross)
283 ltr (net)

Energy Rating: A++

FREEZER FEATURES

Auto defrost
3 full width drawers

DOOR FEATURES

Right & reversible opening

Additional Information

Annual energy consumption: 241kw
Noise: 39dB
Power cut safe rising time: 21
Holiday mode: Yes
Door fixing: BI slide door

Colour

White

Appliance Dimensions (HxWxD) in mm:

Combined: 1842 x 540 x 552
Built-in: 1850 x 560 x 560



Extra Tall Integrated NoFrost Fridge Freezer
SCE8191VTS

KEY FEATURES

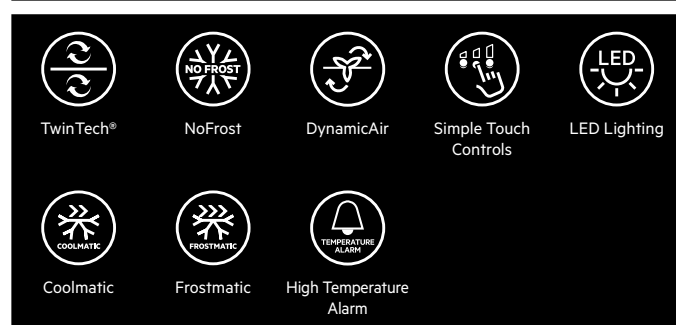

FRIDGE FEATURES

Auto defrost
3 full width + flexi shelf
Fresh box
Dairy compartment with lid
1 half width sliding door shelf
Egg tray: 2 for 6 eggs

Capacity

Fridge:
223 ltr (gross)
219 ltr (net)

Freezer:
73 ltr (gross)
64 ltr (net)

Combined:
296 ltr (gross)
283 ltr (net)

Energy Rating: A+

FREEZER FEATURES

Auto defrost
3 full width drawers

DOOR FEATURES

Right & reversible opening

Additional Information

Annual energy consumption: 307kw
Noise: 39dB
Power cut safe rising time: 21
Holiday mode: Yes
Door fixing: BI slide door

Colour

White

Appliance Dimensions (HxWxD) in mm:

Combined: 1842 x 540 x 552
Built-in: 1850 x 560 x 560

REFRIGERATION

INTEGRATED FRIDGE FREEZERS



Integrated NoFrost Fridge Freezer with Soft Close Doors
SCE8182XNC

KEY FEATURES

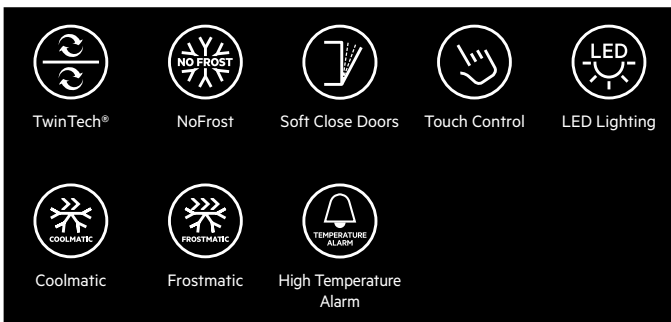

FRIDGE FEATURES

Auto defrost
3 full width + flexi shelf
2 half width salad drawers
Dairy compartment with lid
1 half width sliding door shelf
Egg tray: 2 for 6 eggs

FREEZER FEATURES

Auto defrost
3 full width drawers

DOOR FEATURES

Door open alarm
Right & reversible opening

Capacity

Fridge:
189 ltr (gross)
186 ltr (net)

Freezer:
76 ltr (gross)
61 ltr (net)

Combined:
265 ltr (gross)
247 ltr (net)

Additional Information

Annual energy consumption: 226kw
Noise: 39dB
Power cut safe rising time: 23
Holiday mode: Yes
Door fixing: BI DoD

Colour
White

Appliance Dimensions (HxWxD) in mm:

Combined: 1769 x 556 x 549
Built-in: 1780 x 560 x 550

Energy Rating: A++



Integrated NoFrost Fridge Freezer
SCE8182XTS

KEY FEATURES

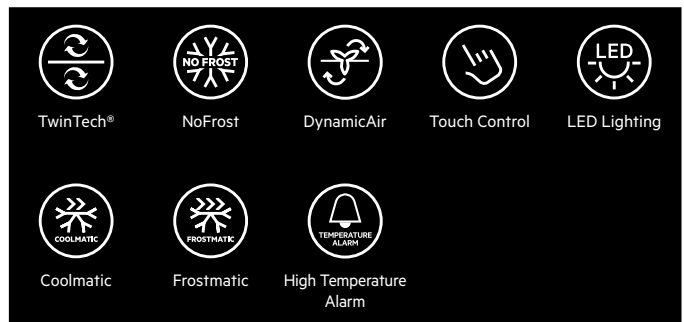

FRIDGE FEATURES

Auto defrost
2 full width + flexi shelf
2 half width salad drawers
Dairy compartment with lid
1 half width sliding door shelf
Egg tray: 2 for 6 eggs

FREEZER FEATURES

Auto defrost
4 full width drawers

DOOR FEATURES

Door open alarm
Right & reversible opening

Capacity

Fridge:
157 ltr (gross)
152 ltr (net)

Freezer:
107 ltr (gross)
87 ltr (net)

Combined:
264 ltr (gross)
239 ltr (net)

Additional Information

Annual energy consumption: 238kw
Noise: 39dB
Power cut safe rising time: 25
Holiday mode: Yes
Door fixing: BI slide door

Colour
White

Appliance Dimensions (HxWxD) in mm:

Combined: 1772 x 540 x 549
Built-in: 1780 x 560 x 550







Energy Rating: A++



Integrated NoFrost Fridge Freezer

SCE8181VNS

KEY FEATURES

 TwinTech®	 NoFrost	 Touch Control	 LED Lighting	 Coolmatic
 Frostmatic	 High Temperature Alarm			

FRIDGE FEATURES

- Auto defrost
- 2 full width + flexi shelf
- 2 half width salad drawers
- Dairy compartment with lid
- 1 half width sliding door shelf
- Egg tray: 2 for 6 eggs

FREEZER FEATURES

- Auto defrost
 - 4 full width drawers
- DOOR FEATURES**
- Door open alarm
 - Right & reversible opening

Capacity

Fridge:
157 ltr (gross)
152 ltr (net)

Freezer:
107 ltr (gross)
87 ltr (net)

Combined:
264 ltr (gross)
239 ltr (net)

Additional Information

Annual energy consumption: 303kw
Noise: 39dB
Power cut safe rising time: 25
Holiday mode: Yes
Door fixing: BI slide door

Colour

White

Energy Rating: A+









Appliance Dimensions (HxWxD) in mm:

Combined: 1772 x 540 x 549
Built-in: 1780 x 560 x 550

Integrated NoFrost Fridge Freezer

SCE8181VTS

KEY FEATURES

 TwinTech®	 NoFrost	 DynamicAir	 Touch Control	 LED Lighting
 Coolmatic	 Frostmatic	 High Temperature Alarm		

FRIDGE FEATURES

- Auto defrost
- 3 full width + flexi shelf
- 2 half width salad drawers
- Dairy compartment with lid
- 1 half width sliding door shelf
- Egg tray: 2 for 6 eggs

FREEZER FEATURES

- Auto defrost
 - 3 full width drawers
- DOOR FEATURES**
- Door open alarm
 - Right & reversible opening

Capacity

Fridge:
197 ltr (gross)
192 ltr (net)

Freezer:
76 ltr (gross)
61 ltr (net)

Combined:
273 ltr (gross)
253 ltr (net)

Additional Information

Annual energy consumption: 291kw
Noise: 39dB
Power cut safe rising time: 21
Holiday mode: Yes
Door fixing: BI slide door

Colour

White

Energy Rating: A+

Appliance Dimensions (HxWxD) in mm:

Combined: 1772 x 540 x 549
Built-in: 1780 x 560 x 550

REFRIGERATION

INTEGRATED FRIDGE FREEZERS



Integrated LowFrost Fridge Freezer

SCB6181XLS

KEY FEATURES

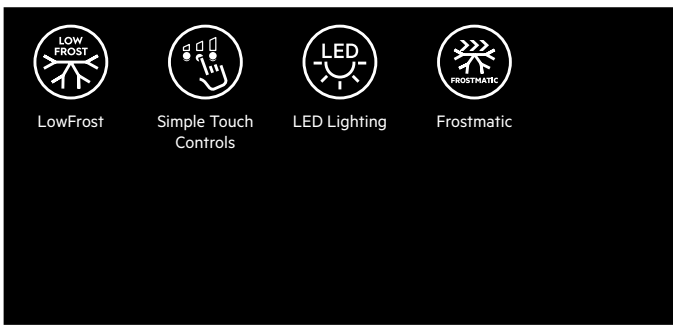

Integrated LowFrost Fridge Freezer

SCB6181VLS

KEY FEATURES

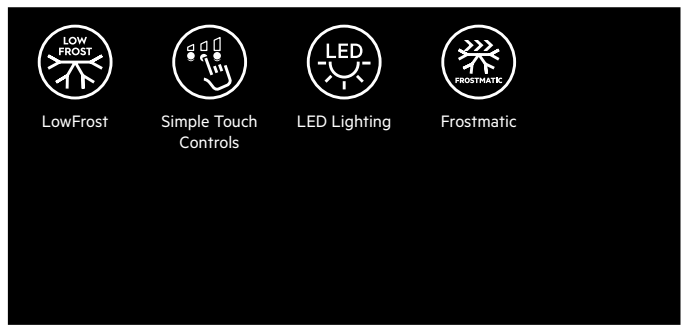

FRIDGE FEATURES

Auto defrost
4 full width + flexi shelf
2 half width salad drawers
Dairy compartment with lid
Egg tray: 2 for 6 eggs

FREEZER FEATURES

Manual defrost
3 full width drawers

DOOR FEATURES

Right & reversible opening

Capacity

Fridge:
199 ltr (gross)
196 ltr (net)

Freezer:
73 ltr (gross)
72 ltr (net)

Combined:
272 ltr (gross)
268 ltr (net)

Additional Information

Annual energy consumption: 291kw
Noise: 36dB
Power cut safe rising time: 22
Holiday mode: Yes
Door fixing: BI slide door

Colour

White

Energy Rating: A+

Appliance Dimensions (HxWxD) in mm:

Combined: 1772 x 540 x 549
Built-in: 1780 x 560 x 550

FRIDGE FEATURES

Auto defrost
3 full width + flexi shelf
2 half width salad drawers
Dairy compartment with lid
1 half width sliding door shelf
Egg tray: 2 for 6 eggs

FREEZER FEATURES

Manual defrost
4 full width drawers

DOOR FEATURES

Right & reversible opening

Capacity

Fridge:
163 ltr (gross)
160 ltr (net)

Freezer:
106 ltr (gross)
106 ltr (net)

Combined:
269 ltr (gross)
266 ltr (net)

Additional Information

Annual energy consumption: 293kw
Noise: 36dB
Power cut safe rising time: 22
Door fixing: BI slide door

Colour

White

Energy Rating: A+

Appliance Dimensions (HxWxD) in mm:

Combined: 1772 x 540 x 549
Built-in: 1780 x 560 x 550



Integrated LowFrost Fridge Freezer

SCB5142VLS

KEY FEATURES

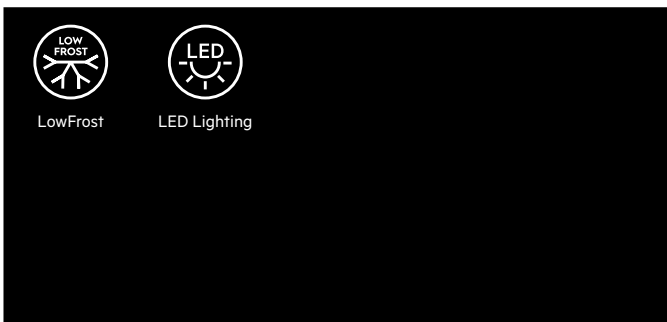

FRIDGE FEATURES

Auto defrost
3 full width + flexi shelf
2 half width salad drawers
Dairy compartment with lid
1 half width sliding door shelf
Egg tray: 2 for 6 eggs

FREEZER FEATURES

Manual defrost
2 full width drawers

DOOR FEATURES

Right & reversible opening

Capacity

Fridge:
163 ltr (gross)
160 ltr (net)

Freezer:
57 ltr (gross)
57 ltr (net)

Combined:
220 ltr (gross)
217 ltr (net)

Additional Information

Annual energy consumption: 204kw
Noise: 35dB
Power cut safe rising time: 20
Door fixing: BI slide door
Mechanical control

Colour

White

Energy Rating: A++

Appliance Dimensions (HxWxD) in mm:

Combined: 1441 x 540 x 549
Built-in: 1446 x 560 x 540

REFRIGERATION

UNDER COUNTER FREEZERS



Integrated Under Counter NoFrost Freezer
ABE6821VNF

Integrated Under Counter Freezer
ABE6822VAF

KEY FEATURES

KEY FEATURES

- NoFrost
- Simple Touch Controls
- Frostmatic
- High Temperature Alarm

- Simple Touch Controls
- Frostmatic
- High Temperature Alarm

FREEZER FEATURES

FREEZER FEATURES

- Auto defrost
- 3 full width drawers
- Telescopic freezer drawers

- Manual defrost
- 3 full width drawers

DOOR FEATURES

- Door open alarm
- Right & reversible opening

DOOR FEATURES

- Door open alarm
- Right & reversible opening

Capacity

Fridge:
86 ltr (gross)
85 ltr (net)

Additional Information

Annual energy consumption: 191kw
Noise: 41dB
Power cut safe rising time: 13
Door fixing: BI UC DoD

Colour

White

Energy Rating: A+

Appliance Dimensions (HxWxD) in mm:
Unit: 815 x 596 x 550
Built-in: 820 x 600 x 550

Capacity

Fridge:
105 ltr (gross)
95 ltr (net)

Additional Information

Annual energy consumption: 147kw
Noise: 38dB
Power cut safe rising time: 29
Door fixing: BI UC DoD

Colour

White



Energy Rating: A++

Appliance Dimensions (HxWxD) in mm:
Unit: 815 x 596 x 550
Built-in: 820 x 600 x 550



Integrated Under Counter Freezer
ABB6821VAF

KEY FEATURES

- 
Simple Touch Controls
- 
Frostmatic
- 
High Temperature Alarm

FREEZER FEATURES

- Manual defrost
- 3 full width drawers

DOOR FEATURES

- Door open alarm
- Right & reversible opening

Capacity

Fridge:
105 ltr (gross)
95 ltr (net)

Additional Information

Annual energy consumption: 187kw
Noise: 38dB
Power cut safe rising time: 29
Door fixing: BI UC DoD

Colour

White

Energy Rating: A+

Appliance Dimensions (HxWxD) in mm:

Unit: 815 x 596 x 550
Built-in: 820 x 600 x 550

UNDER COUNTER FRIDGES



Integrated Under Counter Fridge with 4-Star Freezer Compartment
SFB5821VAF

KEY FEATURES

- 
LED Lighting

FRIDGE FEATURES

- Auto defrost
- 2 full width glass shelves
- 1 full width salad drawer
- Dairy compartment with lid
- 1 half width sliding door shelf
- Egg tray: 1 for 6 eggs

DOOR FEATURES

- Right & reversible opening

Capacity

Fridge:
111 ltr (gross)
109 ltr (net)

Additional Information

Annual energy consumption: 172kw
Noise: 38dB
Power cut safe rising time: 13
Door fixing: BI UC DoD
Mechanical control

Colour

White

Energy Rating: A+

Appliance Dimensions (HxWxD) in mm:

Unit: 815 x 596 x 550
Built-in: 820 x 600 x 550

REFRIGERATION

UNDER COUNTER FRIDGES



Integrated Under Counter Fridge with Ice Box
SFE5822VAF

KEY FEATURES

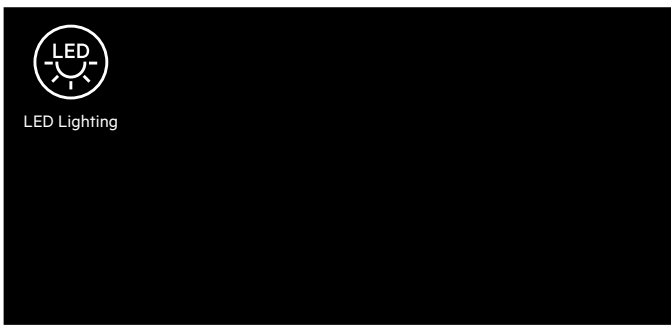

Integrated Under Counter Larder Fridge
SKB5821VAF

KEY FEATURES



FRIDGE FEATURES

Auto defrost
2 full width glass shelves
1 full width salad drawer
Dairy compartment with lid
1 half width sliding door shelf
Egg tray: 1 for 6 eggs

DOOR FEATURES

Right & reversible opening

FRIDGE FEATURES

Auto defrost
3 full width glass shelves
1 full width salad drawer
Dairy compartment with lid
1 half width sliding door shelf
Egg tray: 1 for 6 eggs

DOOR FEATURES

Right & reversible opening

Capacity

Fridge:
111 ltr (gross)
109 ltr (net)

Additional Information

Annual energy consumption: 139kw
Noise: 36dB
Door fixing: BI UC DoD
Mechanical control

Colour

White

Capacity

Fridge:
136 ltr (gross)
133 ltr (net)

Additional Information

Annual energy consumption: 118kw
Noise: 36dB
Door fixing: BI UC DoD
Mechanical control

Colour

White

Energy Rating: A++

Appliance Dimensions (HxWxD) in mm:

Unit: 815 x 596 x 550
Built-in: 820 x 600 x 550

Energy Rating: A+

Appliance Dimensions (HxWxD) in mm:

Unit: 815 x 596 x 550
Built-in: 820 x 600 x 550



Integrated Under Counter Larder Fridge
SKE5822VAF

KEY FEATURES

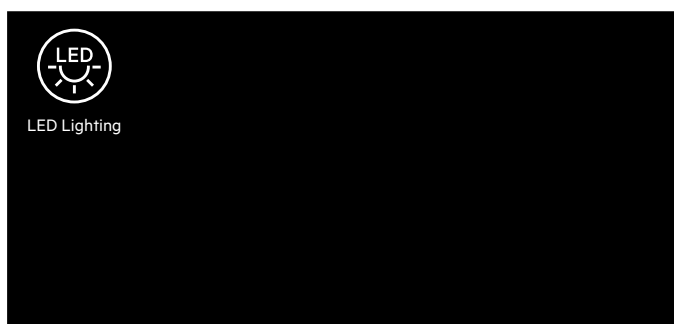

LED
LED Lighting

FRIDGE FEATURES

- Auto defrost
- 3 full width glass shelves
- 1 full width salad drawer
- Dairy compartment with lid
- 1 half width sliding door shelf
- Egg tray: 1 for 6 eggs

Capacity

Fridge:
136 ltr (gross)
133 ltr (net)

DOOR FEATURES

Right & reversible opening

Additional Information

Annual energy consumption: 91kw
Noise: 36dB
Door fixing: BI UC DoD
Mechanical control

Colour

White

Energy Rating: A++

Appliance Dimensions (HxWxD) in mm:

Unit: 815 x 596 x 550
Built-in: 820 x 600 x 550

INTEGRATED FREEZERS



Integrated NoFrost Freezer
ABK8182VNC

KEY FEATURES

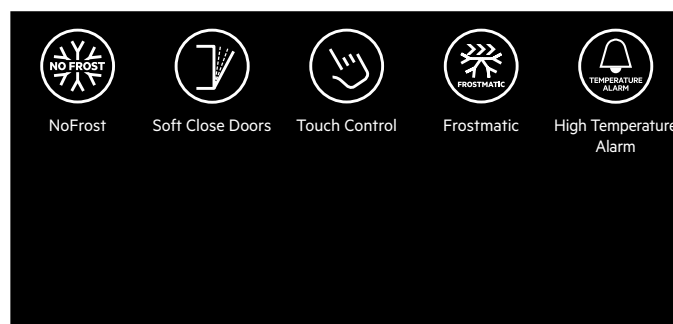

NO FROST **SOFT CLOSE DOORS** **TOUCH CONTROL** **FROSTMATIC** **TEMPERATURE ALARM**
NoFrost Soft Close Doors Touch Control Frostmatic High Temperature Alarm

FREEZER FEATURES

- Auto defrost
- 5 full width drawers

Capacity

Freezer:
216 ltr (gross)
204 ltr (net)

DOOR FEATURES

- Door open alarm
- Right & reversible opening

Additional Information

Annual energy consumption: 238kw
Noise: 39dB
Power cut safe rising time: 24
Door fixing: BI DoD

Colour

White

Energy Rating: A++

Appliance Dimensions (HxWxD) in mm:

Unit: 1769 x 556 x 549
Built-in: 1780 x 560 x 550

REFRIGERATION

INTEGRATED FREEZERS



Integrated NoFrost Freezer

ABE8122VNC

KEY FEATURES

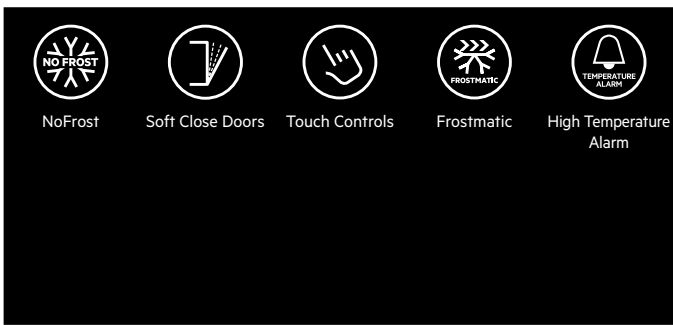

FREEZER FEATURES

Auto defrost
4 full width drawers

DOOR FEATURES

Door open alarm
Right & reversible opening

Capacity

Freezer:
130 ltr (gross)
120 ltr (net)

Additional Information

Annual energy consumption: 183kw
Noise: 39dB
Power cut safe rising time: 22
Door fixing: BI DoD

Colour

White

Energy Rating: A++

Appliance Dimensions (HxWxD) in mm:

Unit: 1224 x 556 x 549
Built-in: 1225 x 556 x 550



LongFresh

The LongFresh feature is a Zero Degree compartment with adjustable temperature settings and separate humidity. To maintain the deep blushing crimson of a fillet of beef, to ensure the sweet freshness of a lobster tail, or to hold the ultimate flavour of fresh fruit they must be treated and chilled with precision. The two Zero Degree compartments in the AEG refrigerator allow you to choose and adjust the humidity and temperature settings in each drawer. Ensure that each element is at peak condition, by chilling them in unique conditions.

INTEGRATED FRIDGES



Integrated LongFresh Fridge with Soft Close Doors
SKK8182VZC

KEY FEATURES

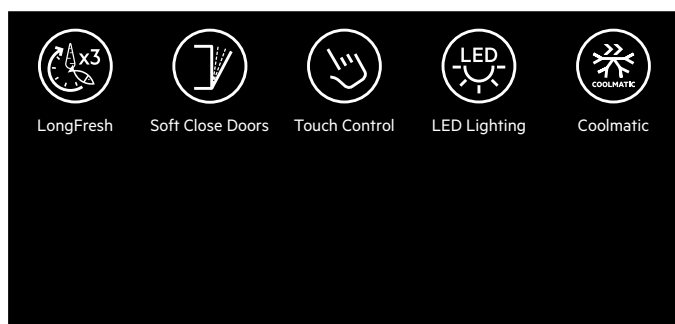

FRIDGE FEATURES

Auto defrost
3 full width + flexi shelf
Dairy compartment with lid
1 half width sliding door shelf
Egg tray: 2 for 6 eggs

DOOR FEATURES

Door open alarm
Right & reversible opening

Capacity

Fridge:
298 ltr (gross)
275 ltr (net)

Additional Information

Annual energy consumption: 130kw
Noise: 37dB
Door fixing: BI DoD

Colour

White

Energy Rating: A++

Appliance Dimensions (HxWxD) in mm:

Unit: 1769 x 556 x 549
Built-in: 1780 x 560 x 550



Integrated Fridge with Soft Close Doors
SKK8182VDC

KEY FEATURES

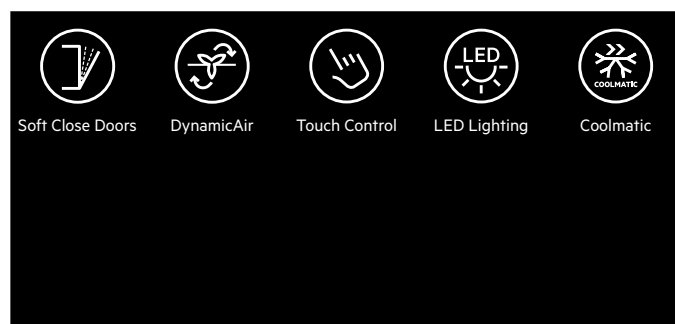

FRIDGE FEATURES

Auto defrost
4 full width + flexi shelf
1 drawer divider Fresh box
Dairy compartment with lid
1 half width sliding door shelf
Egg tray: 2 for 6 eggs

DOOR FEATURES

Door open alarm
Right & reversible opening

Capacity

Fridge:
314 ltr (gross)
310 ltr (net)

Additional Information

Annual energy consumption: 114kw
Noise: 35dB
Holiday mode
Door fixing: BI DoD

Colour

White

Energy Rating: A++

Appliance Dimensions (HxWxD) in mm:

Unit: 1769 x 556 x 549
Built-in: 1780 x 560 x 550

REFRIGERATION





INTEGRATED FRIDGES



Integrated Fridge with Soft Close Doors

SKE8122VAC

KEY FEATURES

			
Soft Close Doors	Touch Control	LED Lighting	Coolmatic

FRIDGE FEATURES

- Auto defrost
- 3 full width + flexi shelf
- 2 half width salad drawers
- Dairy compartment with lid
- 1 half width sliding door shelf
- Egg tray: 2 for 6 eggs

DOOR FEATURES

- Door open alarm
- Right & reversible opening

Capacity

Fridge:
205 ltr (gross)
202 ltr (net)

Additional Information

Annual energy consumption: 103kw
Noise: 35dB
Holiday mode
Door fixing: BI DoD

Colour

White

Energy Rating: A++

Appliance Dimensions (HxWxD) in mm:

Unit: 1219 x 556 x 550
Built-in: 1225 x 560 x 550

AMERICAN SIDE BY SIDES



American Style Fridge Freezer
RMB76111NX

KEY FEATURES

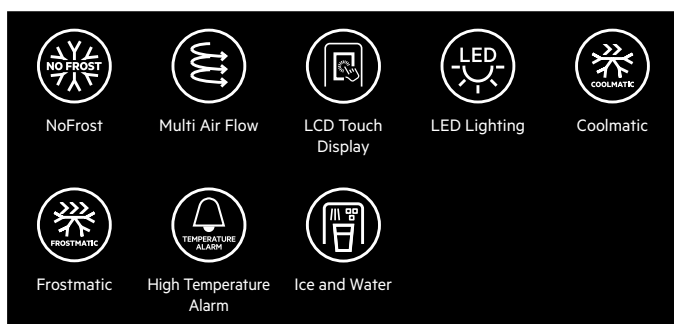

FRIDGE FEATURES

Auto defrost
4 full width glass shelves
Fresh box
Large pull out salad drawer
Dairy compartment with lid
Egg tray

FREEZER FEATURES

Auto defrost
2 full width drawers
DOOR FEATURES
Door open alarm
Side by side door opening
2 shelves

Capacity

Fridge:
380 ltr (gross)
370 ltr (net)

Freezer:
228 ltr (gross)
179 ltr (net)

Combined:
608 ltr (gross)
549 ltr (net)

Additional Information

Annual energy consumption: 467kw
Noise: 43dB
Power cut safe rising time: 10
Holiday mode

Colour

Stainless steel

Energy Rating: A+

Appliance Dimensions (HxWxD) in mm:
1780 x 912 x 738



French Door Fridge Freezer
RMB76311NX

KEY FEATURES

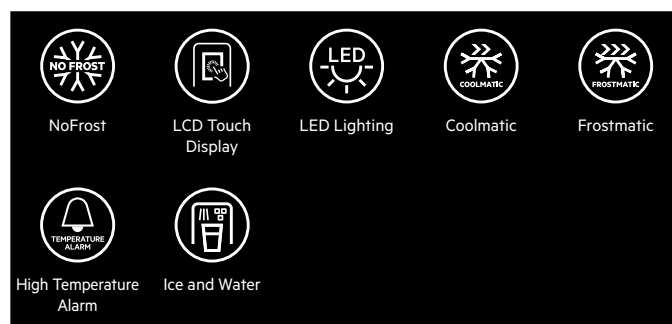

FRIDGE FEATURES

Auto defrost
2 full width glass shelves
2 half width salad drawers
Large pull out salad drawer
2 dairy compartments with lid
Wine rack

FREEZER FEATURES

Auto defrost
2 full width trays + 1 drawer
2 half width trays + 1 drawer
Telescopic freezer drawers
DOOR FEATURES
Left & right door opening

Capacity

Fridge:
436 ltr (gross)
417 ltr (net)

Freezer:
194 ltr (gross)
119 ltr (net)

Combined:
630 ltr (gross)
536 ltr (net)

Additional Information

Annual energy consumption: 410kw
Noise: 43dB
Power cut safe rising time: 12
Holiday mode

Colour

Stainless steel

Energy Rating: A+

Appliance Dimensions (HxWxD) in mm:
1776 x 912 x 765

WINE COOLING

Our Wine Cellar Range has dedicated technology for optimal wine storage, to store your wine bottles at the perfect temperature throughout the cooler.

Our wine cellars have a single temperature zone with a range of 5–20, providing the perfect environment for your wine. The UV protected glass door helps to protect your wine from light damage and our internal fan ensures a stable, consistent temperature.



POWER

LIGHT



RUN



DISPLAY



UP



DOWN



WINE COOLING

WINE COOLERS



Undercounter 46 Bottle Wine Cooler
SWE66001DG

KEY FEATURES



FRIDGE FEATURES

6 full width glass shelves

Capacity

46 bottles

DOOR FEATURES

Right & reversible opening

Additional Information

Annual energy consumption: 149
Energy efficiency index: 54.7
Climate class: N-ST
Noise: 39
Freezing capacity: 0
Power cut safe rising time: 0
Minimum ambient temperature: 16
Holiday mode: No
Bl wide door

Energy Rating: A

Appliance Dimensions (HxWxD) in mm:

Unit: 820 x 595 x 565
Built-in: 822 x 600 x 550



Undercounter 18 Bottle Wine Cooler
SWE63001DG

KEY FEATURES



FRIDGE FEATURES

6 full width glass shelves

Capacity

18 bottles

DOOR FEATURES

Right & reversible opening

Additional Information

Annual energy consumption: 140
Energy efficiency index: 54.6
Climate class: N-ST
Noise: 39
Freezing capacity: 0
Power cut safe rising time: 0
Minimum ambient temperature: 16
Holiday mode: No
Bl wide door

Energy Rating: A

Appliance Dimensions (HxWxD) in mm:

Unit: 820 x 294 x 571
Built-in: 822 x 300 x 550



Undercounter 7 Bottle Wine Cooler

SWE61501DG

KEY FEATURES



Wine

Wine Temp

UV Glass

Simple Touch
Controls

LED Lighting

FRIDGE FEATURES

6 full width glass shelves

Capacity

7 bottles

DOOR FEATURES

Right opening

Additional Information

Annual energy consumption: 137

Energy efficiency index: 0

Climate class: N-ST

Noise: 35

Freezing capacity: 0

Power cut safe rising time: 0

Minimum ambient temperature: 16

Holiday mode: No

BI wide door

Energy Rating: A

Appliance Dimensions (HxWxD) in mm:

Unit: 870 x 148 x 526

Built-in: 872 x 150 x 550

OVENS

However you like to cook and whatever your favourite dishes, there's an AEG oven that's just right for you.

Featuring our intelligent technology, every oven makes it effortless and enjoyable to create great tasting food, exactly the way you like it.

IN THIS SECTION

Single Ovens	42-48
Built-in Double Ovens	49
Built Under Double Ovens	50
Compacts	52-65
Blackline Range	66-71



COMMAND
WHEEL OVEN
CONTROL



STEAMPRO



SENSE COOK

RARE, MEDIUM, WELL DONE. AT YOUR COMMAND.



Command Wheel

An innovative Command Wheel removes the need for a busy dashboard and makes the cooking experience simple and streamlined for perfection on a plate, every time.

The latest furniture trends are becoming more linear and we have designed our products in line with that. We've also included more glass and less stainless steel for a seamless finish.





SenseCook

By precisely measuring the core temperature of your food, the Food Sensor lets you know when your rare, medium or well done meat is ready. As well as cooking fish, casseroles and vegetables just the way you like them.



SurroundCook®

Expect even, every time with SurroundCook®. Every part of your dish receives the exact consistent heat that it needs.



Pyrolytic Self Cleaning

A total self-cleaning function, that heats up to 500°C and turns food residue to ash.

STEAM. YOUR NEW STANDARD FOR FLAVOUR.

For maximum flavour, add steam.

By adding steam to traditional heat, our range of ovens ensures your dishes are cooked to your exact preference.



Why steam?

- **Prevents flavour exchange**
Stops flavour exchange between different dishes.
- **Food stays moist**
Prevents food from drying out.
- **Preservation**
Preserves nutrients, vitamins and minerals.
- **Evenly cooked**
Cooks food more evenly from surface to core.
- **More efficient**
Delivers heat more efficiently to the food than dry, hot air, so the temperature can be lower.

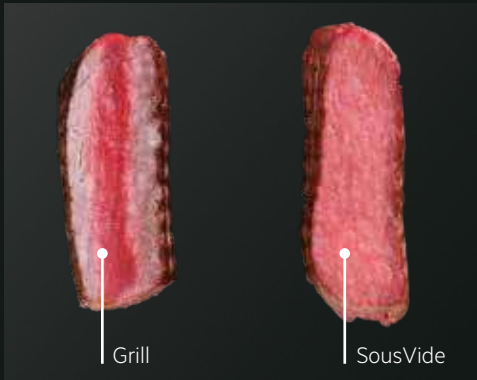

SteamPro

SteamPro, with SousVide means you can create tastier and healthier dishes. Cook with absolute purity, sealing in all the aromas, taste and nutrients under vacuum, then applying gentle steam heat to cook delicious dishes.



SteamBoost

Turn flavour up to full, whether you are baking, roasting or steaming with SteamBoost. The right amount of steam locks in the natural moisture to deliver juicy and succulent dishes.



SteamCrisp

SteamCrisp, by combining steam and traditional heat, food is cooked gently from the outside to the centre, enhancing food taste and achieving better results. Perfect for all your favourite roasting and baking recipes.

A GUIDE TO COOKING ICONS

KEY FEATURES



SteamPro

An multifunctional oven that also provides you with the SousVide function, a powerful tool that has been used by professional chefs for many years.



SteamBoost

The introduction of steam makes all the difference. Locking in the natural moisture to deliver a whole range of juicy and succulent dishes including meat, fish, casseroles and vegetables – even desserts.



SteamCrisp

By combining steam and traditional heat, food is cooked gently from the outside to the centre, enhancing food taste and achieving better results.



SteamBake™

Adds a bit of steam for the right colour and crust, improving all of your baking results.



SurroundCook®

Hot air fan that circulates the air more effectively than an conventional oven so that your food gets evenly cooked anywhere in the oven.



SenseCook

Food sensor that adapts to what you are cooking and helps you get the results your are aiming for. Just tell the oven how you want your dish cooked and the oven will let you know once your food has reached the right temperature.



Multifunction

Multifunction ovens have all of the familiar cooking functions, including our extra large hot air fan.



Dual Multifunction

Both oven cavities are multifunctional, meaning that they have all of the traditional cooking functions including True Fan.



Command Wheel

The Command Wheel gives you an intuitive way to operate all the cooking settings. It swiftly responds to your actions so that you always have control of every step of the cooking process.



ProSight Controls

Full-touch electronic control panel – simple to operate and beautifully designed.



Retractable Controls

High quality finish stainless steel retractable knobs.



Pyrolytic

A total self-cleaning oven that heats up to 500°C and turns food residue to ash.



CataFan

The Fan Cover with catalytic surface activated at high temperature supports you with removing all stains and grime on hardly accessible areas.



Soft Motion

Ensures a smooth and soundless door closing delivering a premium feeling time after time.



Catalytic Liners

The catalytic lining absorbs the grease from cooking and is activated by regular heating to 220°C. The grease residue is oxidised leaving the catalytic surface clean.



Enamel Liners

Ultra smooth enamel interior that significantly facilitates easy cleaning.



XXL

All of our single ovens have an extra large capacity, allowing you to cook on all 5 levels simultaneously.



Telescopic Runners

Allows you to pull the shelves smoothly out of the oven. This enables you to efficiently and safely access the contents of your oven.



Fully Programmable

Precise timer that switches off the oven at the time you require. Ideal for dishes with a long cooking process.



3 Vacuum Settings

Seal your food from 50% – 99% efficiency. Making sure that no precious marinade will leave the bag or that unnecessary oxygen enters it.



Non-Vented Installation

Self ventilating microwaves, allows for more flexibility when installing.



800w Quartz Grill

Flexible cooking thanks to microwave functions and integrated quartz grill.

FUNCTIONS



SousVide Cooking

SousVide cooking is an old cooking technology which is used by professional chefs to cook vacuum packed food slowly at a low, very accurately controlled temperature.



Full Steam

The SteamBoost oven with Full Steam function makes more of the flavours within your food. Combining all of traditional oven functions with the added benefit of steam.



Humidity High

The function is suitable for cooking delicate dishes like custards, flans, terrines and fish.



Humidity Medium

The function is suitable for cooking stewed and braised meat as well as bread and sweet yeast dough. Due to the combination of steam and heat the meat gets a juicy and tender texture and yeast dough bakes get a crispy and shiny surface.



Humidity Low

The function is suitable for meat, poultry, oven dishes and casseroles. Thanks to the combination of steam and heat, meat gets a tender and juicy texture along with a crusty surface.



True Fan Cooking

Our true fan cooking system gently circulates hot air through the oven cavity. As the oven heats up faster, lower temperatures and shorter cooking times are used to achieve those delicious results.



Conventional Cooking

Top and bottom elements heat the oven providing traditional cooking on one shelf position, which is ideal for baking breads or fruitcakes.



Bottom Heat

Oven is heated by the bottom element only. Food is gently reheated, ideal for pies and pastries as it keeps the pastry crisp.



Turbo Grilling

Heat from the top element is circulated by the fan, sealing and crisping the food.



Grilling

Fully controllable powerful grill, ideal for family sized portions of food.



Steam Assisted Fan Cooking

An improved version of the traditional True Fan cooking, combining steam with an extra large hot air fan.



Pizza Setting

Designed to ensure pastry bases, quiches and pizzas are cooked to your taste.



Moist Fan Baking

Retains moisture within the ovens, thus achieving light fluffy results whilst using the oven in an energy efficient way.



Slow Cooking

Two slow cook options, dependent on the quantity of food being cooked. Low temperature combined with patience will guarantee a good result.



Defrost

Defrost your frozen food gently in half the usual time. Hot air is quickly circulated inside the oven cavity.



Au Gratin

For dishes such as lasagne or potato gratin. Also to gratinate and brown.



Bread Baking

Optimum temperature and environment for baking yeast mixtures. Using radiant heat and steam to bake a variety of loaves to your taste.



Dough Proving

Creates the perfect environment to assist bread baking by proving your yeast mixture correctly.



Eco Roasting

Economical setting for roasting large joints or poultry. Simply select the appropriate cooking time depending on the weight of the food, and the oven automatically switches off once the cooking is complete.



Pyrolysis

A total self-cleaning function that heats up to 500°C and turns food residue to ash.



Quarter Steam & Heat

25% steam and 75% heat locks in moisture and browns the outside for irresistible flavours.



Microwave & Grill

Combines traditional microwave and grill function.



Defrost by Weight

Take the guesswork away and defrost your food by weighing it during the process.



Auto Favourite

The Auto favourite function has 3 pre-set functions, these are Soften Butter, Melt Chocolate and Mug Cake. You can overwrite these with your favourite recipes.



Child Lock

Setting the child lock function will prevent your little ones to switch on the oven.

SINGLE OVENS

SteamPro, with SousVide allows you to create tastier and healthier dishes. Cook with absolute purity, sealing in all the aromas, taste and nutrients under vacuum, then applying gentle steam heat to cook delicious dishes.

STEAM OVENS



SousVide Multifunction Oven with Command Wheel Control
BSK892330M

KEY FEATURES

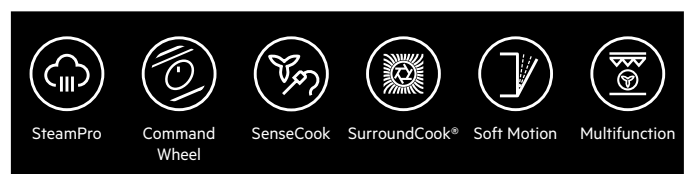

OVEN FUNCTIONS

SousVide Cooking	Bottom Heat
Full Steam	Pizza Setting
Humidity High	Moist Fan Baking
Humidity Medium	Slow Cooking
Humidity Low	Defrost
True Fan Cooking	Au Gratin
Conventional Cooking	Bread Baking
Turbo Grilling	Dough Proving
Grilling	

Model Features

Steam cleaning	Quadruple door glazing
Enamel liners	Telescopic runners
Fully programmable timer	MaxiTray
TFT display	Steam set
70 ltr oven capacity	Patisserie tray
Fast heat up	Humidity sensor
Double halogen lighting	30°C – 230°C

Energy Rating: A++

Appliance/Built-in Dimensions (HxWxD) in mm:
594 x 595 x 567 / 590 x 560 x 550

Vac Sealer

The AEG vacuum sealer drawer lets you be a SousVide pro chef at home, by sealing in the flavour, moisture and nutrients of ingredients until you are ready to cook them to perfection.





SousVide Multifunction Oven

BSK792320M

KEY FEATURES

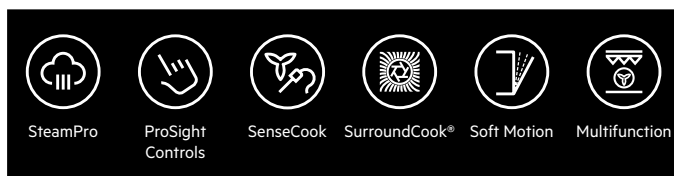

OVEN FUNCTIONS

SousVide Cooking	Bottom Heat
Full Steam	Pizza Setting
Humidity High	Moist Fan Baking
Humidity Medium	Slow Cooking
Humidity Low	Defrost
True Fan Cooking	Au Gratin
Conventional Cooking	Bread Baking
Turbo Grilling	Dough Proving
Grilling	

Model Features

Steam cleaning	Quadruple door glazing
Enamel liners	Telescopic runners
Fully programmable timer	MaxiTray
White Touch Control	Grill pan/trivet
70 ltr oven capacity	Steam set
Fast heat up	Dripping pan
Double halogen lighting	30°C – 230°C

Energy Rating: A+

Appliance/Built-in Dimensions (HxWxD) in mm:

594 x 595 x 567 / 590 x 560 x 550



Full Steam Oven with Command Wheel Control

BSK882320M

KEY FEATURES

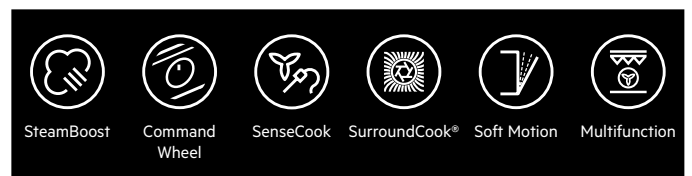

OVEN FUNCTIONS

Full Steam	Moist Fan Baking
Humidity High	Slow Cooking
Humidity Low	Defrost
True Fan Cooking	Au Gratin
Conventional Cooking	Bread Baking
Turbo Grilling	Dough Proving
Grilling	
Bottom Heat	
Pizza Setting	

Model Features

Steam cleaning	Quadruple door glazing
Enamel liners	Telescopic runners
Fully programmable timer	MaxiTray
TFT display	Steam set
70 ltr oven capacity	Patisserie tray
Fast heat up	30°C – 230°C
Double halogen lighting	

Energy Rating: A+

Appliance/Built-in Dimensions (HxWxD) in mm:

594 x 595 x 567 / 590 x 560 x 550

SINGLE OVENS

STEAM OVENS



Premier Partner
EXCLUSIVE

Multifunction Steam Oven

BSK78232PM

KEY FEATURES

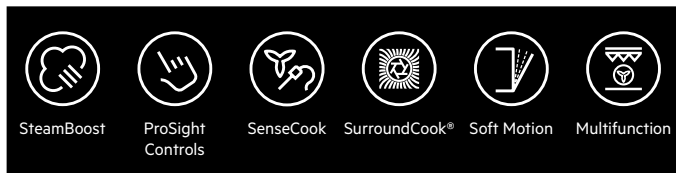

OVEN FUNCTIONS

Full Steam	Moist Fan Baking
Humidity High	Slow Cooking
Humidity Low	Defrost
True Fan Cooking	Bread Baking
Conventional Cooking	Dough Proving
Turbo Grilling	
Grilling	
Bottom Heat	
Pizza Setting	

Model Features

Steam cleaning	Quadruple door glazing
Enamel liners	Telescopic runners
Fully programmable timer	MaxiTray
White Touch Control	Grill pan/trivet
70 ltr oven capacity	Steam set
Fast heat up	Dripping pan
Double halogen lighting	30°C – 230°C

Energy Rating: A+

Appliance/Built-in Dimensions (HxWxD) in mm:

594 x 595 x 567 / 590 x 560 x 550

QUARTER STEAM OVENS



Quarter Steam Oven with Pyrolytic Cleaning

BSK874320M

KEY FEATURES

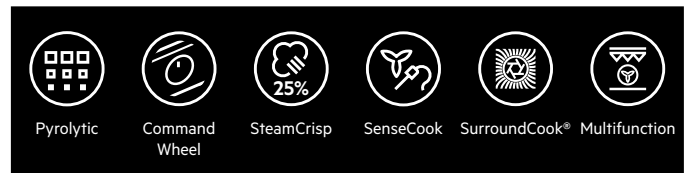

OVEN FUNCTIONS

True Fan Cooking	Pyrolysis
Conventional Cooking	Steam Assisted Fan Cooking
Turbo Grilling	Slow Cooking
Grilling	Au Gratin
Bottom Heat	Bread Baking
Pizza Setting	Dough Proving
Humidity Low	
Moist Fan Baking	
Defrost	

Model Features

Fully programmable timer	Grill pan/trivet
TFT display	Dripping pan
71 ltr oven capacity	30°C – 300°C
Fast heat up	Telescopic runners
Double halogen lighting	Soft motion
Quadruple door glazing	
MaxiTray	

Energy Rating: A+

Appliance/Built-in Dimensions (HxWxD) in mm:

594 x 595 x 567 / 590 x 560 x 550



Quarter Steam Oven with Pyrolytic Self Cleaning
BSK774320M

KEY FEATURES

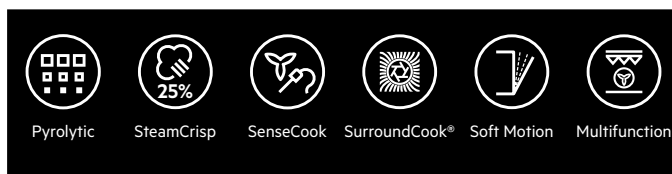

OVEN FUNCTIONS

True Fan Cooking	Dough Proving
Conventional Cooking	Au Gratin
Turbo Grilling	Humidity Low
Grilling	Pyrolysis
Bottom Heat	Slow Cooking
Pizza Setting	
Moist Fan Baking	
Defrost	
Bread Baking	

Model Features

Fully programmable timer	Grill pan/trivet
White LED display	Dripping pan
71 ltr oven capacity	30°C – 300°C
Fast heat up	Telescopic runners
Double halogen lighting	Touch Control
Quadruple door glazing	
MaxiTray	

Energy Rating: A+

Appliance/Built-in Dimensions (HxWxD) in mm:

594 x 595 x 567 / 590 x 560 x 550

PYROLYTIC SELF CLEANING OVENS



Pyrolytic Self Cleaning Multifunction Oven
BPK842720M

KEY FEATURES

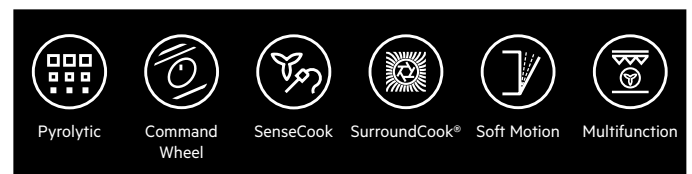

OVEN FUNCTIONS

True Fan Cooking	Dough Proving
Conventional Cooking	Au Gratin
Turbo Grilling	Bread Baking
Grilling	Pyrolysis
Bottom Heat	
Pizza Setting	
Moist Fan Baking	
Defrost	
Slow Cooking	

Model Features

Fully programmable timer	MaxiTray
TFT display	Grill pan/trivet
71 ltr oven capacity	Dripping pan
Fast heat up	30°C – 300°C
Lighting	
Telescopic runners	
Quadruple door glazing	

Energy Rating: A+

Appliance/Built-in Dimensions (HxWxD) in mm:

594 x 595 x 567 / 590 x 560 x 550

SINGLE OVENS

PYROLYTIC SELF CLEANING OVENS



Pyrolytic Self Cleaning Multifunction Oven

BPK742320M

KEY FEATURES

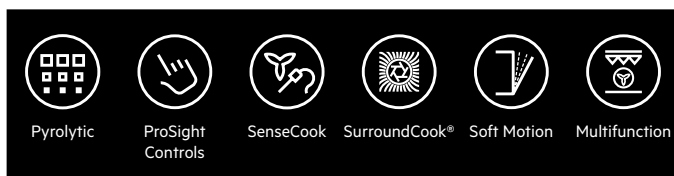

OVEN FUNCTIONS

True Fan Cooking	Dough Proving
Conventional Cooking	Au Gratin
Turbo Grilling	Bread Baking
Grilling	Pyrolysis
Bottom Heat	
Pizza Setting	
Moist Fan Baking	
Defrost	
Slow Cooking	

Model Features

Fully programmable timer	MaxiTray
White LED display	Grill pan/trivet
71 ltr oven capacity	Dripping pan
Fast heat up	30°C – 300°C
Double halogen lighting	Telescopic runners
Quadruple door glazing	
5 shelves	

Energy Rating: A+

Appliance/Built-in Dimensions (HxWxD) in mm:

594 x 595 x 567 / 590 x 560 x 550



Side Hinged Multifunction Oven with Pyrolytic Self Cleaning

BPK744L21M

KEY FEATURES

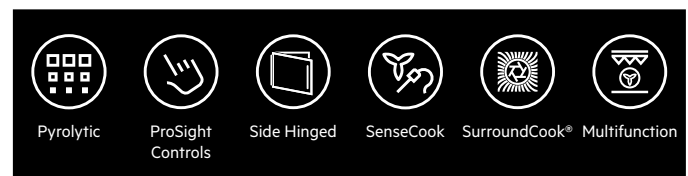

OVEN FUNCTIONS

True Fan Cooking	Dough Proving
Conventional Cooking	Au Gratin
Turbo Grilling	Bread Baking
Grilling	Eco Roasting
Bottom Heat	Pyrolysis
Pizza Setting	
Moist Fan Baking	
Defrost	
Slow Cooking	

Model Features

Fully programmable timer	Dripping pan
White LED display	30°C – 300°C
71 ltr oven capacity	Telescopic runners
Fast heat up	
Double halogen lighting	
Quadruple door glazing	
MaxiTray	

Energy Rating: A+

Appliance/Built-in Dimensions (HxWxD) in mm:

594 x 594 x 568 / 600 x 560 x 550

Also available: BPK744R21M – Right side hinges

PYROLYTIC STEAMBAKE™ OVENS



Premier Partner
EXCLUSIVE

SteamBake™ Oven with Pyrolytic Self Cleaning
BPK55632PM

KEY FEATURES

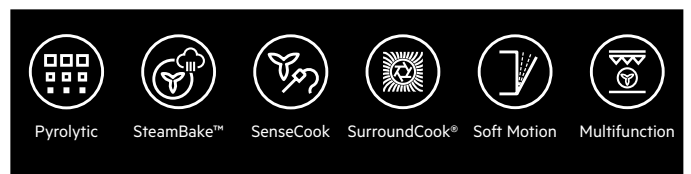

OVEN FUNCTIONS

- True Fan Cooking
- Conventional Cooking
- Turbo Grilling
- Grilling
- Bottom Heat
- Pizza Setting
- Moist Fan Baking
- Defrost
- Pyrolysis

Model Features

- Fully programmable timer
- White LED display
- 71 ltr oven capacity
- Fast heat up
- Single halogen lighting
- Quadruple door glazing
- MaxiTray
- Grill pan/trivet
- Dripping pan
- 30°C – 300°C

Energy Rating: A+

Appliance/Built-in Dimensions (HxWxD) in mm:
594 x 595 x 567 / 590 x 560 x 550



SteamBake™

SteamBake™ enhances your baking results, by making the bakes soft and tender inside, while the outside gets a delicious golden colour and a perfect tasty crust.



Standard oven

SteamBake™ oven

SINGLE OVENS



SteamBake™ Oven with Pyrolytic Self Cleaning

BPK351020M

KEY FEATURES



OVEN FUNCTIONS

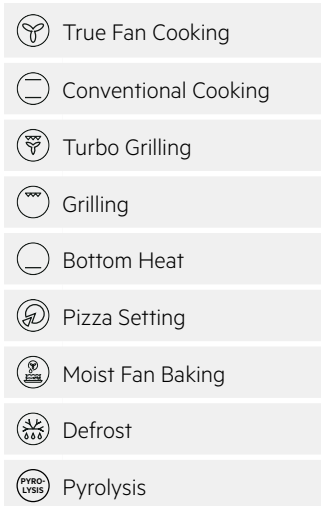

Model Features

Fully programmable timer	Dripping pan
White LED display	30°C – 300°C
71 ltr oven capacity	
Single halogen lighting	
Quadruple door glazing	
MaxiTray	
Grill pan/trivet	

Energy Rating: A+

Appliance/Built-in Dimensions (HxWxD) in mm:

594 x 595 x 567 / 590 x 560 x 550



Premier Partner
EXCLUSIVE

SteamBake™ Oven with CataFan

BCK45631PM

KEY FEATURES

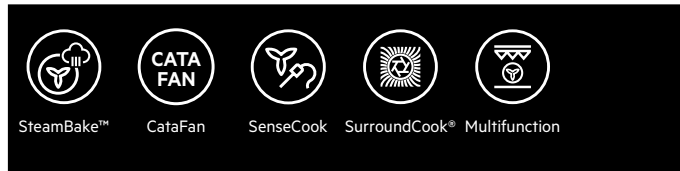

OVEN FUNCTIONS

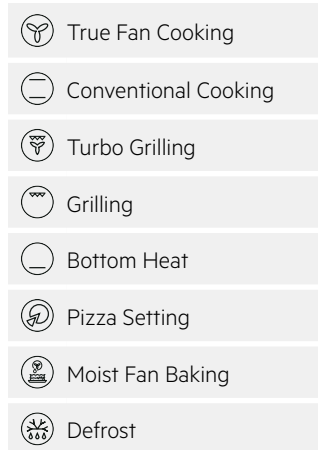

Model Features

Fully programmable timer	Dripping pan
White LED display	50°C – 275°C
71 ltr oven capacity	Telescopic runners
Single halogen lighting	Touch buttons on timer
Triple door glazing	
MaxiTray	
Grill pan/trivet	

Energy Rating: A

Appliance/Built-in Dimensions (HxWxD) in mm:

594 x 595 x 567 / 590 x 560 x 550

BUILT-IN DOUBLE OVENS

SURROUNDcook® MULTIFUNCTION OVENS

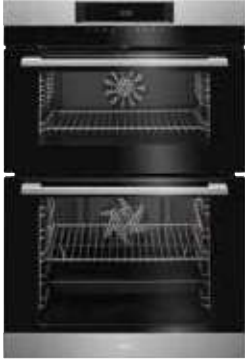

SurroundCook® Multifunction with ProSight Touch Controls
DCK731110M

KEY FEATURES

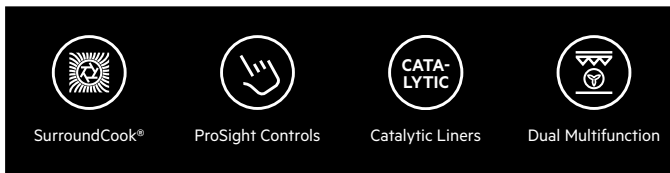

TOP OVEN FUNCTIONS



MAIN OVEN FUNCTIONS

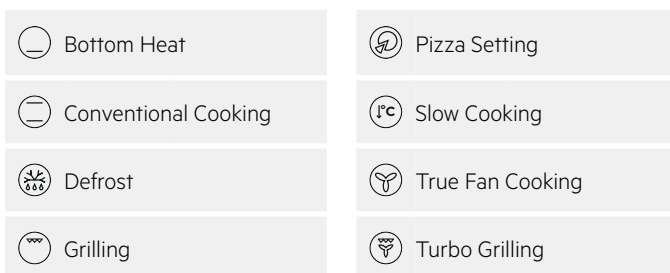

Model Features

Fully programmable timer	4/4 shelf positions
White LED display	MaxiTray
39 ltr top oven capacity	Grill pan/trivet/dripping pan
61 ltr bottom oven capacity	Telescopic runners
Single oven lights	30°C – 300°C
Triple door glazing	

Energy Rating: A/A

Appliance/Built-in Dimensions
(HxWxD) in mm:

888 x 594 x 568 / 875 x 560 x 550



SurroundCook® Multifunction with Retractable Controls
DCK431110M

KEY FEATURES



TOP OVEN FUNCTIONS

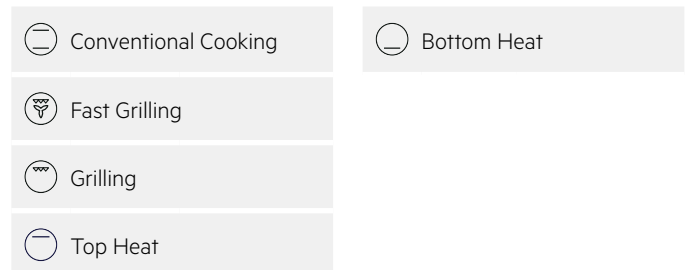

MAIN OVEN FUNCTIONS

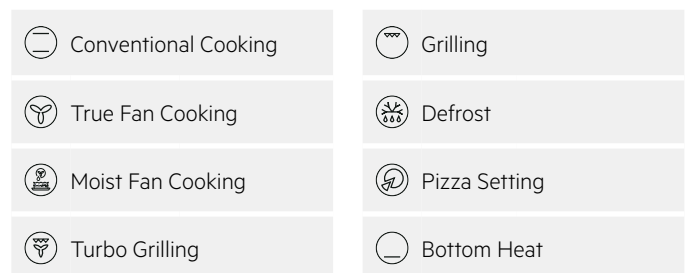

Model Features

Fully programmable timer	4/5 shelf positions
White LED display	MaxiTray
43 ltr top oven capacity	Grill pan/dripping pan
68 ltr bottom oven capacity	50°C – 275°C
Single oven lights	
Double door glazing	

Energy Rating: A/A

Appliance/Built-in Dimensions
(HxWxD) in mm:

888 x 594 x 568 / 875 x 560 x 550

BUILT UNDER DOUBLE OVENS

SURROUNDCOOK® MULTIFUNCTION OVENS



SurroundCook® Multifunction with ProSight Touch Controls

DUK731110M

KEY FEATURES

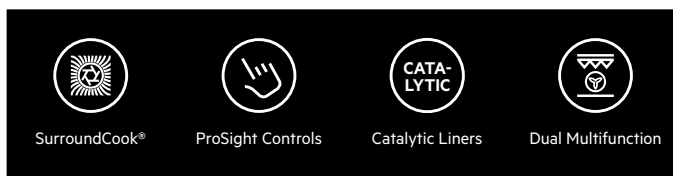

TOP OVEN FUNCTIONS

True Fan Cooking	Pizza Setting
Turbo Grilling	Slow Cooking
Grilling	Defrost
Bottom Heat	

MAIN OVEN FUNCTIONS

Bottom Heat	Pizza Setting
Conventional Cooking	Slow Cooking
Defrost	True Fan Cooking
Grilling	Turbo Grilling

Model Features

Fully programmable timer	4/4 shelf positions
ProSight Controls	MaxiTray
39 ltr top oven capacity	Grill pan/dripping pan
46 ltr bottom oven capacity	50°C – 275°C
Single oven lights	
Triple door glazing	

Energy Rating: A/A

Appliance/Built-in Dimensions (HxWxD) in mm:

715 x 594 x 568 / 720 x 600 x 550



AEG

COMPACT RANGE

With our widest range of high performance appliances, you can mix and match everything you want – the way you want – and it all aligns beautifully with a single, stylish design.

The Compact range also fits perfectly with our full size appliances.



Square Alignment Compacts

Create your ideal kitchen in a combination to suit your needs. By grouping your compact appliances in a cluster, a column or a sleek horizontal run you create your own, individual look.

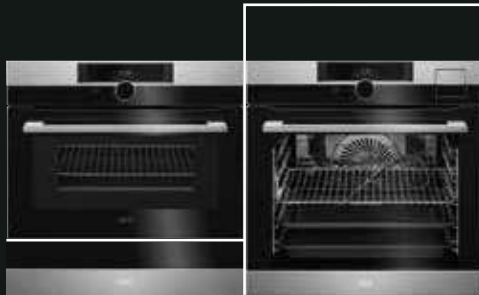

Horizontal Alignment Oven and Compacts

Compact Appliance, Warming Draw or Vac sealer and an AEG Single Oven.

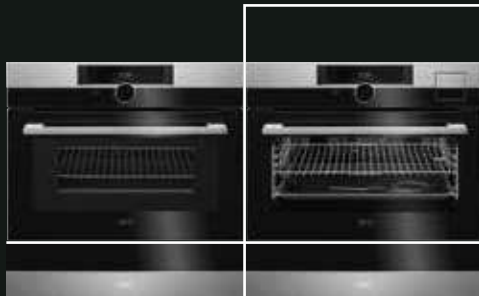

Horizontal Alignment Compacts

Two compact appliances with two warming draws or vacuum sealers.



Vertical Alignment Oven and Compact

Compact above an AEG single oven.

COMPACTS

However you like to create in the kitchen, we have a Compact appliance to suit your preferences.

Whether you want to roast, bake, grill, microwave or cook with steam, our high performance ovens and vacuum sealer drawers ensure you can serve great tasting dishes every time.

The combination of drawers with our Compact range match those of our full-size ovens, so you don't need to compromise.

COMPACT OVENS WITH MICROWAVE



Compact Multifunction Oven with Microwave

KMK861000M

KEY FEATURES



OVEN FUNCTIONS

True Fan Cooking	Bread Baking
Conventional Cooking	Au Gratin
Turbo Grilling	Dough Proving
Grilling	Eco Roasting
Bottom Heat	Slow Cooking
Pizza Setting	
Defrost	
Fast Grilling	
Microwave Function	

Model Features

Fully programmable timer

White LED display

4.3 ltr oven capacity

Single halogen lighting

Quadruple door glazing

MaxiTray

Dripping pan

Grill pan/trivet

30°C – 230°C

Energy Rating: –

Appliance/Built-in Dimensions (HxWxD) in mm:

455 x 595 x 567 / 450 x 560 x 550



Premier Partner
EXCLUSIVE

Compact Multifunction Oven with Microwave

KMK761000M

KEY FEATURES



OVEN FUNCTIONS

True Fan Cooking	Bread Baking
Conventional Cooking	Au Gratin
Turbo Grilling	Dough Proving
Grilling	Eco Roasting
Bottom Heat	Slow Cooking
Pizza Setting	
Defrost	
Fast Grilling	
Microwave Function	

Model Features

Fully programmable timer 30°C – 230°C
 White LED display
 43 ltr oven capacity
 Single halogen lighting
 Quadruple door glazing
 MaxiTray
 Dripping pan

Energy Rating: –

Appliance/Built-in Dimensions (HxWxD) in mm:

455 x 595 x 567 / 450 x 560 x 550

Compact Multifunction Oven with Microwave

KMK565000M

KEY FEATURES

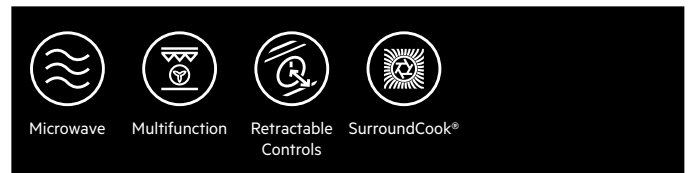

OVEN FUNCTIONS

True Fan Cooking
Conventional Cooking
Turbo Grilling
Grilling
Bottom Heat
Pizza Setting
Defrost
Fast Grilling
Microwave Function

Model Features

Fully programmable timer Touch buttons on timer
 White LED display
 43 ltr oven capacity
 Single halogen lighting
 Quadruple door glazing
 MaxiTray
 30°C – 230°C

Energy Rating: –

Appliance/Built-in Dimensions (HxWxD) in mm:

455 x 595 x 567 / 450 x 560 x 550

COMPACTS

COMPACT MICROWAVE OVENS



Compact Microwave Oven with Grill

KMK721000M

KEY FEATURES

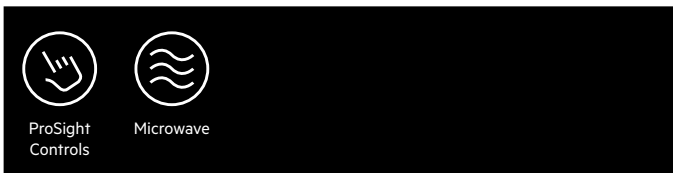

OVEN FUNCTIONS

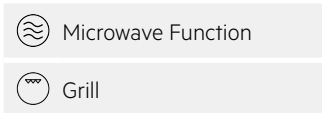

Model Features

- Fully programmable timer
- White LED display
- 43 ltr oven capacity
- Single halogen lighting
- Quadruple door glazing
- 30°C – 230°C

Energy Rating: –

Appliance/Built-in Dimensions (HxWxD) in mm:

455 x 595 x 567 / 450 x 560 x 550

COMPACT OVENS



Compact SousVide Oven

KSK892220M

KEY FEATURES

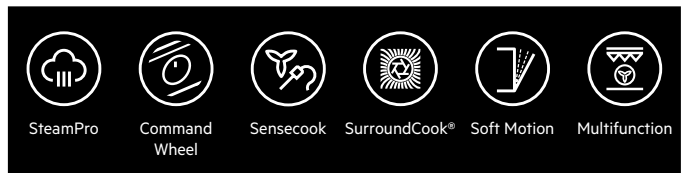

OVEN FUNCTIONS

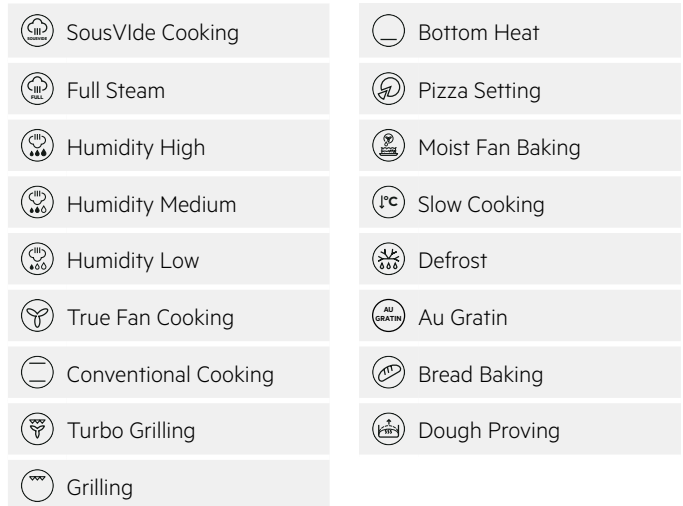

Model Features

- Steam cleaning
- Enamel liners
- Fully programmable timer
- TFT display
- 43 ltr oven capacity
- Fast heat up
- Single halogen lighting
- Quadruple door glazing
- MaxiTray
- Grill pan/trivet
- Patisserie tray
- Steam set
- Humidity sensor
- 30°C – 230°C

Energy Rating: A+

Appliance/Built-in Dimensions (HxWxD) in mm:

455 x 595 x 567 / 450 x 560 x 550



Compact Full Steam Oven

KSK882220M

KEY FEATURES

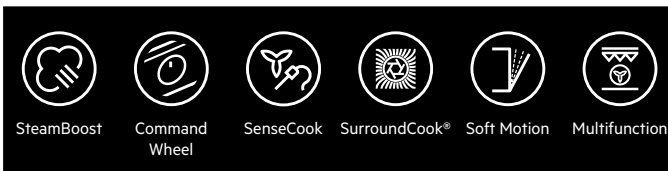

OVEN FUNCTIONS

Full Steam	Defrost
True Fan Cooking	Au Gratin
Conventional Cooking	Bread Baking
Turbo Grilling	Dough Proving
Grilling	Fast Grilling
Bottom Heat	Quarter Steam & Heat
Pizza Setting	
Moist Fan Baking	
Slow Cooking	

Model Features

Steam cleaning	MaxiTray
Fully programmable timer	Grill pan/trivet
TFT display	30°C – 230°C
43 ltr oven capacity	Dripping pan
Fast heat up	Steam set
Single halogen lighting	Enamel liners
Quadruple door glazing	

Energy Rating: A+

Appliance/Built-in Dimensions (HxWxD) in mm:

455 x 595 x 567 / 450 x 560 x 550



Compact Full Steam Oven

KSK782220M

KEY FEATURES

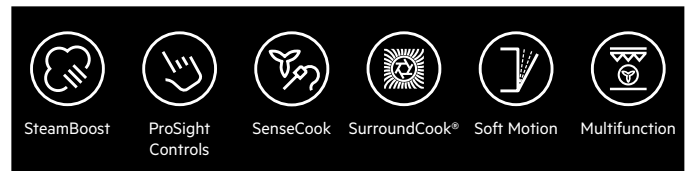

OVEN FUNCTIONS

Full Steam	Defrost
True Fan Cooking	Au Gratin
Conventional Cooking	Bread Baking
Turbo Grilling	Dough Proving
Grilling	Fast Grilling
Bottom Heat	Quarter Steam & Heat
Pizza Setting	
Moist Fan Baking	
Slow Cooking	

Model Features

Steam cleaning	MaxiTray
Fully programmable timer	Grill pan/trivet
White LED display	Steam set
43 ltr oven capacity	Dripping pan
Fast heat up	30°C – 230°C
Single halogen lighting	Enamel liners
Quadruple door glazing	

Energy Rating: A+

Appliance/Built-in Dimensions (HxWxD) in mm:

455 x 595 x 567 / 450 x 560 x 550

COMPACTS

COMPACT OVENS



Compact Multifunction Oven with Pyrolytic Self Cleaning KPK842220M

KEY FEATURES

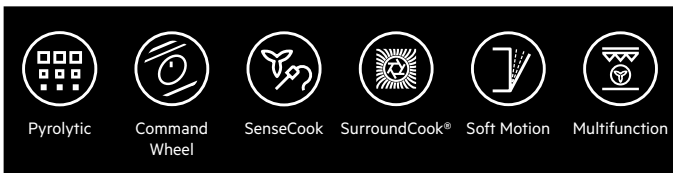

OVEN FUNCTIONS

Full Steam	Au Gratin
True Fan Cooking	Dough Proving
Conventional Cooking	Eco Roasting
Turbo Grilling	Fast Grilling
Grilling	Slow Cooking
Bottom Heat	Bread Baking
Pizza Setting	
Moist Fan Baking	
Pyrolysis	

Model Features

Fully programmable timer	Grill pan/trivet
TFT display	Dripping pan
43 ltr oven capacity	30°C – 300°C
Fast heat up	
Single halogen lighting	
Quadruple door glazing	
MaxiTray	

Energy Rating: A+

Appliance/Built-in Dimensions (HxWxD) in mm:

455 x 595 x 567 / 450 x 560 x 550

Compact Multifunction Oven with Pyrolytic Self Cleaning KPK742220M

KEY FEATURES



OVEN FUNCTIONS

True Fan Cooking	Au Gratin
Conventional Cooking	Dough Proving
Turbo Grilling	Eco Roasting
Grilling	Fast Grilling
Bottom Heat	
Pizza Setting	
Moist Fan Baking	
Defrost	
Pyrolysis	

Model Features

Fully programmable timer	Grill pan/trivet
White LED display	30°C – 300°C
43 ltr oven capacity	
Fast heat up	
Single halogen lighting	
Quadruple door glazing	
MaxiTray	

Energy Rating: A+

Appliance/Built-in Dimensions (HxWxD) in mm:

455 x 595 x 567 / 450 x 560 x 550

COFFEE MACHINES



Coffee Machine with Command Wheel Control

KKK994500M

KEY FEATURES

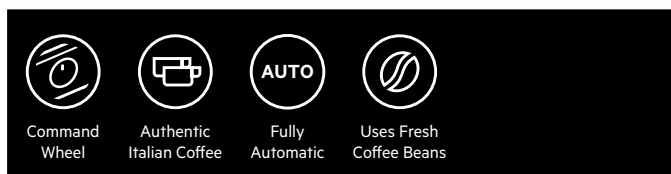

FUNCTIONS

Espresso	Latte Macchiato
Cappuccino	Long Coffee
Cappuccino Plus	Warm Milk
Caffè Latte	Ristretto
Caffè Macchiato	Steamer
Espresso Lungo	Jug Function
Espresso Macchiato	Two Cups
Flat White	
Tea Water	

Model Features

Coffee jug	2.4 ltr water tank
Thermal milk container	400 gr grinder capacity
Descaler	Quadruple LED lighting
Cleaning brush	
Coffee powder spoon	
Telescopic runners + soft closing	
Water softener	

Energy Rating: –

Appliance/Built-in Dimensions (HxWxD) in mm:

455 x 595 x 361 / 450 x 560 x 550

Coffee Machine with Touch Control

KKK884500M

KEY FEATURES

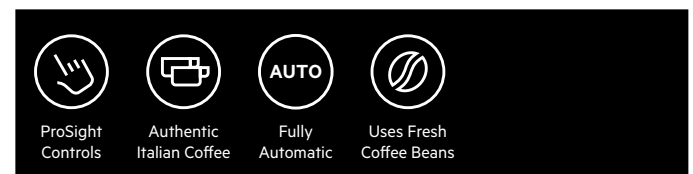

FUNCTIONS

Espresso
Cappuccino
Tea Water
Two Cups
Jug Function
Steamer

Model Features

Coffee jug
Milk container
Descaler
1.8 ltr water tank
200 gr grinder capacity
Dual LED lighting

Energy Rating: –

Appliance/Built-in Dimensions (HxWxD) in mm:

455 x 595 x 567 / 450 x 560 x 550

COMPACTS

WARMING DRAWERS



29cm Warming Drawer

KDK912922M

KEY FEATURES

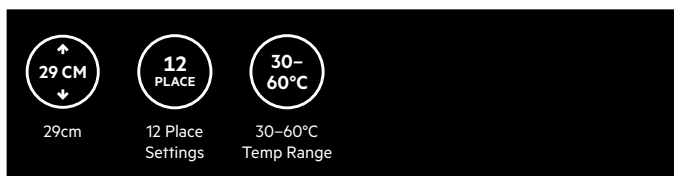

FUNCTIONS

Cups and Glass Warming (40°C)	Food Warming (80°C Max)
Plate Warming (60°C)	Defrosting (30°C Max)

Model Features

Variable temperature control	Rotary control knob
On/off LED	Heating element
Anti-slip mat	Fan air circulation

Appliance Dimensions (HxWxD) in mm:

295 x 595 x 535

Built-in Dimensions (HxWxD) in mm:

295 x 560 x 550

29cm Warming Drawer

KDE912922M

KEY FEATURES

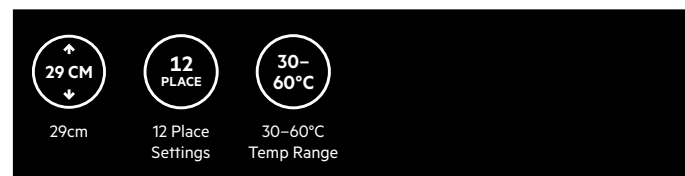

FUNCTIONS

Cups and Glass Warming (40°C)	Food Warming (80°C Max)
Plate Warming (60°C)	Defrosting (30°C Max)

Model Features

Variable temperature control	Rotary control knob
On/off LED	Heating element
Anti-slip mat	Fan air circulation

Appliance Dimensions (HxWxD) in mm:

295 x 595 x 535

Built-in Dimensions (HxWxD) in mm:

295 x 560 x 550



14cm Warming Drawer

KDK911422M

KEY FEATURES

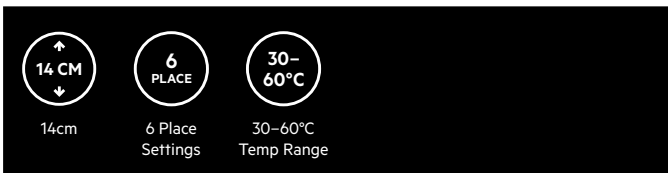

FUNCTIONS

Cups and Glass Warming (40°C)	Food Warming (80°C Max)
Plate Warming (60°C)	Defrosting (30°C Max)

Model Features

Variable temperature control	Rotary control knob
On/off LED	Heating element
Anti-slip mat	Fan air circulation

Appliance Dimensions (HxWxD) in mm:

131 x 595 x 500

Built-in Dimensions (HxWxD) in mm:

139 x 560 x 550



14cm Warming Drawer

KDE911422M

KEY FEATURES

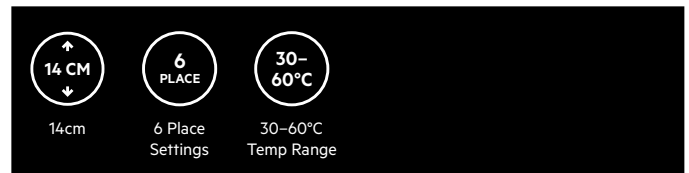

FUNCTIONS

Cups and Glass Warming (40°C)	Food Warming (80°C Max)
Plate Warming (60°C)	Defrosting (30°C Max)

Model Features

Variable temperature control	Rotary control knob
On/off LED	Heating element
Anti-slip mat	Fan air circulation

Appliance Dimensions (HxWxD) in mm:

131 x 595 x 500

Built-in Dimensions (HxWxD) in mm:

139 x 560 x 550

COMPACTS

WARMING DRAWERS



SOUSVIDE VACUUM SEALERS



14cm Warming Drawer

KD91405M

KEY FEATURES

14cm	6 Place Settings	30-60°C Temp Range	Personalised Cabinetry Panel

FUNCTIONS

Cups and Glass Warming (40°C)	Food Warming (80°C Max)
Plate Warming (60°C)	Defrosting (30°C Max)

Model Features

Variable temperature control	Rotary control knob
On/off LED	Heating element
Anti-slip mat	Fan air circulation

Appliance Dimensions (HxWxD) in mm:
125 x 594 x 549

Built-in Dimensions (HxWxD) in mm:
140 x 560 x 539

14cm Vacuum Sealer

KDK911423M

KEY FEATURES

Touch Control	White LEDs	3 Vacuum Settings

FUNCTIONS

Marinating/Infusion	Min. Vacuum Setting
Max. Vacuum Setting	Sealing Time Displayed
Med. Vacuum Setting	

Appliance Dimensions (HxWxD) in mm:
131 x 595 x 510

Built-in Dimensions (HxWxD) in mm:
139 x 560 x 550

MICROWAVE OVENS

The AEG microwave ovens are fully built-in with a design alignment with our Ovens. These fully built-in microwave ovens have an intuitive touchscreen control panel that features a simple wipe – clean surface. The touch sensitive panel lets you change functions and timings in seconds too.



Solo Microwave
MBE2658S-M

KEY FEATURES

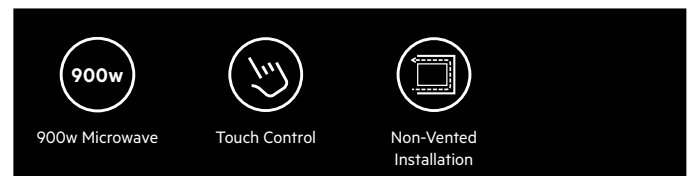

FUNCTIONS

Microwave	Child Lock
Defrost by Weight	
Auto Favourite	

Additional Features

26 ltr capacity	White LED display
32.5cm turntable	90min timer
LED lighting	

Colour: Stainless steel fascia panel

Appliance Dimensions

(HxWxD) in mm:
459 x 596 x 404



Built-in Dimensions

(HxWxD) in mm:
450 x 562 x 500







Solo Microwave
MBB1756S-M

KEY FEATURES

 800w Microwave	 Touch Control	 Non-Vented Installation
---	--	--

FUNCTIONS

 Microwave	 Child Lock
 Defrost by Weight	
 Auto Favourite	

Additional Features

17 ltr capacity	White LED display
27cm turntable	90min timer
LED lighting	

Colour: Stainless steel fascia panel

Appliance Dimensions

(HxWxD) in mm:

371 x 594 x 316

Built-in Dimensions

(HxWxD) in mm:

360 x 562 x 300

All AEG microwave ovens can be installed in all cabinetry, whether it be non-ventilated or ventilated kitchen cabinets, making them perfect for kitchen upgrades or replacements.



INTRODUCING THE AEG BLACKLINE RANGE





BLACKLINE RANGE



SousVide BlackLine Oven

BSE792320B

KEY FEATURES

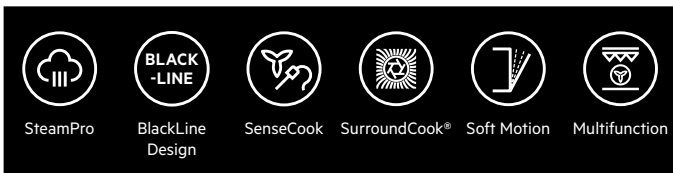

OVEN FUNCTIONS

SousVide Cooking	Bottom Heat
Full Steam	Pizza Setting
Humidity High	Moist Fan Baking
Humidity Medium	Slow Cooking
Humidity Low	Defrost
True Fan Cooking	Au Gratin
Conventional Cooking	Bread Baking
Turbo Grilling	Dough Proving
Grilling	

Model Features

Steam cleaning	Telescopic runners
Enamel liners	MaxiTray
Fully programmable timer	Grill pan/trivet
70 ltr oven capacity	Patisserie tray
Fast heat up	Steam set
Double halogen lighting	Dripping pan
Quadruple door glazing	30°C – 230°C

Energy Rating: A+

Appliance/Built-in Dimensions (HxWxD) in mm:

594 x 595 x 567 / 590 x 560 x 550

Pyrolytic Self Cleaning Multifunction Oven

BPK742320B

KEY FEATURES

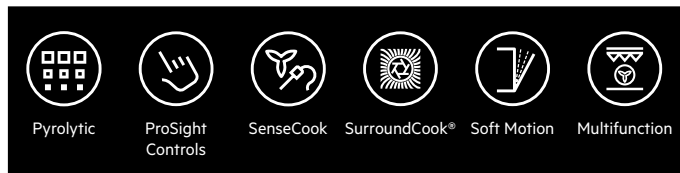

OVEN FUNCTIONS

True Fan Cooking	Dough Proving
Conventional Cooking	Au Gratin
Turbo Grilling	Bread Baking
Grilling	Pyrolysis
Bottom Heat	
Pizza Setting	
Moist Fan Baking	
Defrost	
Slow Cooking	

Model Features

Fully programmable timer	Grill pan/trivet
White LED display	Dripping pan
71 ltr oven capacity	30°C – 300°C
Fast heat up	Telescopic runners
Double halogen lighting	
Quadruple door glazing	
MaxiTray	

Energy Rating: A+

Appliance/Built-in Dimensions (HxWxD) in mm:

594 x 595 x 567 / 590 x 560 x 550



Compact BlackLine Multifunction Oven with Microwave
KME761000B

KEY FEATURES



OVEN FUNCTIONS

True Fan Cooking	Bread Baking
Conventional Cooking	Au Gratin
Turbo Grilling	Dough Proving
Grilling	Eco Roasting
Bottom Heat	Slow Cooking
Pizza Setting	
Defrost	
Fast Grilling	
Microwave Function	

Model Features

Fully programmable timer 30°C – 230°C
 White LED display
 43 ltr oven capacity
 Single halogen lighting
 Quadruple door glazing
 MaxiTray
 Dripping pan

Energy Rating: –

Appliance/Built-in Dimensions (HxWxD) in mm:

455 x 595 x 567 / 450 x 560 x 550

BLACKLINE RANGE



BlackLine Coffee Machine with Touch Control

KKE884500B

KEY FEATURES

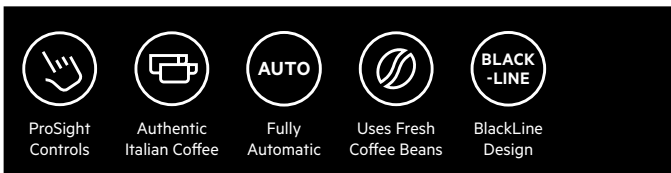

FUNCTIONS

Espresso
Cappuccino
Tea Water
Two Cups
Jug Function
Steamer

Model Features

- Coffee jug
- Milk container
- Descaler
- 1.8 ltr water tank
- 200 gr grinder capacity
- Dual LED lighting

Energy Rating: –

Appliance/Built-in Dimensions (HxWxD) in mm:

455 x 595 x 361 / 450 x 560 x 550

14cm Warming Drawer

KDE911422B

KEY FEATURES

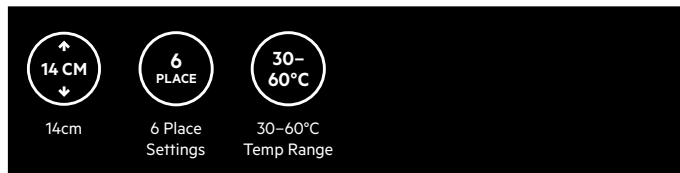

FUNCTIONS

Cups and Glass Warming (40°C)	Food Warming (80°C Max)
Plate Warming (60°C)	Defrosting (30°C Max)

Model Features

- Variable temperature control
- Rotary control knob
- On/off LED
- Heating element
- Anti-slip mat
- Fan air circulation

Appliance Dimensions (HxWxD) in mm:

131 x 595 x 500

Built-in Dimensions (HxWxD) in mm:



139 x 560 x 550



14cm Vacuum Sealer

KDE911423B

KEY FEATURES

		
ProSight Controls	White LEDs	3 Vacuum Settings

FUNCTIONS

Marinating/Infusion	Min. Vacuum Setting
Max. Vacuum Setting	Sealing Time Displayed
Med. Vacuum Setting	

Appliance Dimensions

(HxWxD) in mm:

131 x 595 x 510

Built-in Dimensions

(HxWxD) in mm:

139 x 560 x 550

HOBS

At AEG we believe that a hob should look as good as it performs. Which is why all our induction hobs are designed not just to bring out the best in your cooking, but also to give you all the flexibility you need while cooking and to look fantastic in your kitchen.

IN THIS SECTION

Induction	80–89
ComboHobs	90
Ceramic	91
Gas Hobs	92–101
Mixed Fuel Hobs	102
CrystalLine	103–105



TFT Touch control



SenseFry®



MaxiSense®



Slim Installation

TAKE THE GUESS WORK OUT OF FRYING



SenseFry®

SenseFry® delivers accurate and consistent frying results every time.

Preset frying levels automatically sense, control and regulate the cooking temperature to deliver great taste and texture every time.

Simply select the food type, frying level, and the SenseFry® will take care of the rest.





Pure Black Design

Aligns perfectly with every kitchen style to match the clean design of your kitchen. This hob has a unique, pure black surface – with absolutely no markings apart from a subtle on/off button.



Hob²Hood

The AEG Hob²Hood adapts to your cooking to keep your kitchen free of steam and vapours without you even having to touch it.



Slim Installation

The slim, space-saving design embeds into a work surface of any depth, even with a drawer below.

PLACE IT WHEREVER YOU WANT

The ComboHob combines an induction hob and an integrated hood into one single product. So you can place the hob wherever you want without having to install a hood above it, giving you many creative options for individual kitchen design.





Easy Installation

The unique 2in1 design of the ComboHob makes it possible to integrate it anywhere in the kitchen.



Hob²Hood

Built directly in to the AEG ComboHob, Hob²Hood adapts to your cooking to keep your kitchen free of steam and vapours without you even having to touch it.



Easy Cleaning and Maintenance

The beautiful glass surface is durable and easy to maintain, only needing a quick wipe to clean up.

A GUIDE TO HOB ICONS

KEY FEATURES



Touch Control

Efficient touch controls enable you to set the hob's heat level precisely, while its flat surface is easy to clean.



TFT Touch Display

A single, full colour touchscreen provides complete control over the hob. Monitor live feedback for each zone and adjust the settings accordingly.



DirekTouch Slider

This hob's direct-access heat controls enable you to switch directly to exactly the right temperature with one touch. Simply touch the correct level on the slide control.



SenseFry®

Use the intelligent touchscreen on the SenseFry® induction hob to select the food and desired result. Rare, medium or well-done.



Rotary DirekTouch

Touch controls in the familiar design of rotary of knobs. The DirekTouch function allows you to switch to the exact right temperature with one touch.



Rotary

Classic rotary control knobs.



MaxiSense®

The MaxiSense® induction hob has self-sizing cooking zones. Each zone detects the size and shape of the pan you're using, however large or small.



FlexiBridge

A multi-purpose zone that allows you to customize your own cooking area, combining up to 4 segments with a consistent and even heat distribution.



Double Bridge

Two zones can be paired at the touch of a button, providing a single bridge for cooking. By automatically aligning to share both temperature and time settings, it's optimised for using large pots and pans at once.



PowerSlide

From boiling to simmering to keeping warm: when you need repeated quick heat changes to create a dish. Simply slide your pan from heat to heat.



Stop & Go

A function that reduces all zones in operation to a keep warm setting.



TripleZone

Triple extendable zone, optimized for cooking with a wide range of pot sizes.



Hob²Hood

Hob²Hood automatically turns on your cooker hood and lights when you start using the hob. The cooker hood will adjust according to the cooking levels on the induction zones.



Pure Black Design

Unique hob with pure black design. The hob controls and cooking zones are visible only when needed. When not in use, the surface is clean black, nothing to disturb the kitchen design.



Cast Iron Supports

Cast iron pan supports provide a robust and durable cooking support with professional design. Safe, long lasting and easy to clean.



Extendable Zone

Extendable zone, optimised for cooking with a wide range of pot sizes.



Slim Installation

AEG induction hobs have the slimmest platform on the market, allowing a worktop as thin as 28mm with an oven beneath the hob.



Easy Installation

Our Optifix™ spring system is self-installing and self-centering. Simply place the hob into your cut out.

KEY FEATURES



Easy Clean

Because the surface around the pans stays cool as you cook, you can get rid of spills as you go along. Nothing gets burnt on and there's nowhere for dirt to hide.



Minute Minder

Perfect cooking results guaranteed by setting the cooking time length and has an acoustic signal to let you know it has finished.



Auto Ignition

Total control of the ignition through a single-handed operation of turning the knob to automatically light the hob.



Flush Burner

Flush burners are easy to remove and dishwasher safe. Ensuring that cleaning the hob is as simple as possible.



Vertical Flame

Vertical Flame ensures the heat is evenly distributed on the bottom of the pan, making it 20% more efficient than standard burners.



Single Bridge

Two zones can be paired at the touch of a button, providing a single bridge for cooking. By automatically aligning to share both temperature and time settings, it's optimised for using large pots and pans at once.

FUNCTIONS



Cook Assist

An innovative assisted cooking function, select the dish and the desired result – rare, medium, well-done – to ensure consistent frying.



Count Up Timer

Set a reminder or use the count-up timer to keep in control of your cooking.



Minute Minder

Each induction cooking zone has an independent 99 minute timer. The timer will switch the zone off after the time has elapsed.



Eco Timer

Energy saving timer that switches off the zone and uses residual heat to complete the last few minutes of cooking.



Zone Booster

Power booster function to reach high temperatures extra fast.



AutoMax

The hob will apply full output of heat at the beginning, then it will automatically drop to the required setting.



Pot Detection

The user interface is not visible until a pot is placed on the hob.



Auto Off

Safety mechanism that turn off the hob after a given time, depending on the selected heat setting.



Melting

A gentle melting function, perfect for chocolate or butter.



Burners

Number of burners.



Wok Burner

Extra large burner designed for a large wok.

HOBS

The SenseFry® Induction Hob delivers accurate and consistent frying results every time.

It uses an integrated intelligent touchscreen, allowing you to select the food and desired level of cooking.

The pre-set frying levels can automatically sense, control and regulate the temperature to deliver great taste and texture.

INDUCTION HOBS



80cm SenseFry® Hob

IAE84850FB

KEY FEATURES



FUNCTIONS



Additional Features

Residual heat indicators	Bevelled 4 sides
Child lock	Electricity loading 7350W
Red LEDs	

Energy Rating: N/A

Appliance Dimensions (HxWxD) in mm:

44 x 810 x 520

Built-in Dimensions (HxW) in mm:

780 x 490

Plancha Grill

Turn your hob in an instant to a barbecue and get perfect grill taste all year round with the Plancha Grill. Heat is distributed fast and consistently across the plate, ensuring all ingredients are grilled evenly wherever you place them. Now you can grill steaks to perfection!

Discover more about the Mastery Collection: aeg.co.uk/taste/discover/the-mastery-collection/





80cm ActiveTouch Hob

IKE85651FB

KEY FEATURES

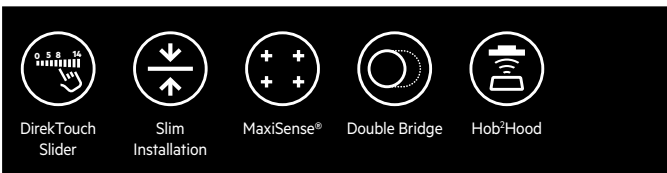

FUNCTIONS

Pot Detection	Stop & Go
Count Up Timer	Auto Off
Minute Minder	
Eco Timer	
Zone Booster	

Additional Features

Residual heat indicators	Bevelled 4 sides
Child lock	Electricity loading 7350W
Red and White LEDs	

Energy Rating: N/A

Appliance Dimensions (HxWxD) in mm:

44 x 810 x 520

Built-in Dimensions (HxW) in mm:

780 x 490

80cm PURE2 Induction Hob

HKP87420FB

KEY FEATURES

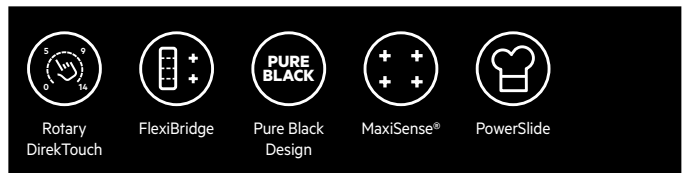

FUNCTIONS

AutoMax	Zone Booster
Count Up Timer	Stop & Go
Minute Minder	Auto Off
Eco Timer	

Additional Features

Residual heat indicators	Bevelled 4 sides
Child lock	Electricity loading 7400W
Red LEDs	

Energy Rating: N/A

Appliance Dimensions (HxWxD) in mm:

50 x 780 x 520

Built-in Dimensions (HxW) in mm:

750 x 490

HOBS

INDUCTION HOBS



80cm PURE1 Induction Hob

HK874400FB

KEY FEATURES

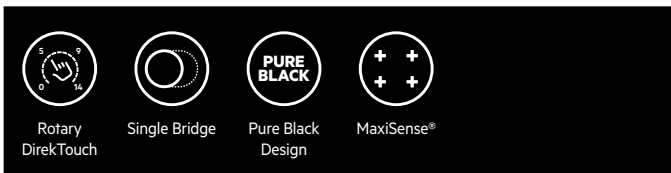

FUNCTIONS

AutoMax	Zone Booster
Pot Detection	Stop & Go
Count Up Timer	Auto Off
Minute Minder	
Eco Timer	

Additional Features

Residual heat indicators	Bevelled 4 sides
Child lock	Electricity loading 7400W
Red LEDs	

Energy Rating: N/A

Appliance Dimensions (HxWxD) in mm:

50 x 780 x 520

Built-in Dimensions (HxW) in mm:

750 x 490

80cm MaxiSense® Induction Hob

IKE84471FB

KEY FEATURES

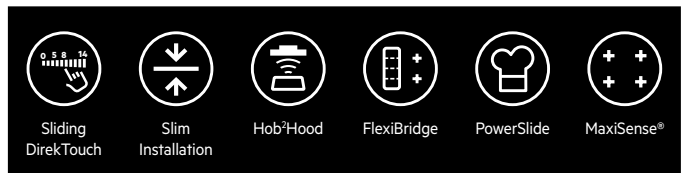

FUNCTIONS

AutoMax	Zone Booster
Count Up Timer	Stop & Go
Minute Minder	Auto Off
Eco Timer	

Additional Features

Residual heat indicators	Bevelled 4 sides
Child lock	Electricity loading 7350W
Red LEDs	

Energy Rating: N/A

Appliance Dimensions (HxWxD) in mm:

44 x 780 x 520

Built-in Dimensions (HxW) in mm:

750 x 490



80cm MaxiSense® Induction Hob

IKE85431FB

KEY FEATURES

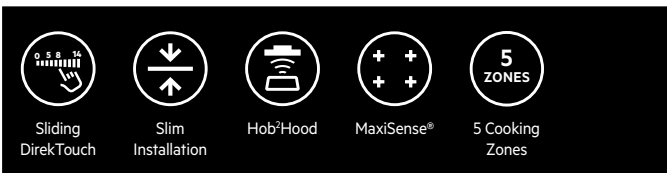

FUNCTIONS

AutoMax	Zone Booster
Count Up Timer	Stop & Go
Minute Minder	Auto Off
Eco Timer	

Additional Features

Residual heat indicators	Bevelled 4 sides
Child lock	Electricity loading 7350W
Red LEDs	

Energy Rating: N/A

Appliance Dimensions (HxWxD) in mm:

44 x 780 x 520

Built-in Dimensions (HxW) in mm:

750 x 490

80cm MaxiSense® Induction Hob

IKB84431FB

KEY FEATURES

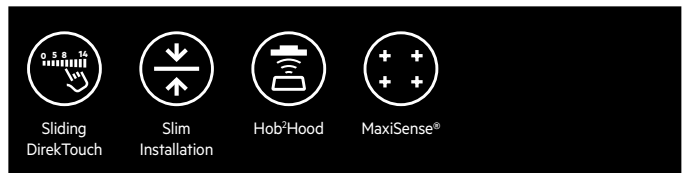

FUNCTIONS

AutoMax	Zone Booster
Count Up Timer	Stop & Go
Minute Minder	Auto Off
Eco Timer	

Additional Features

Residual heat indicators	Bevelled 4 sides
Child lock	Electricity loading 7350W
Red LEDs	

Energy Rating: N/A

Appliance Dimensions (HxWxD) in mm:

44 x 780 x 520

Built-in Dimensions (HxW) in mm:

750 x 490

HOBS

INDUCTION HOBS



80cm MaxiSense® Induction Hob

IKB84401FB

KEY FEATURES

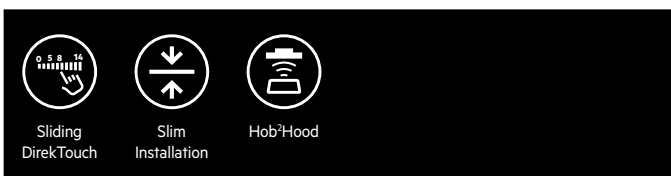

FUNCTIONS

AutoMax	Zone Booster
Count Up Timer	Stop & Go
Minute Minder	Auto Off
Eco Timer	

Additional Features

Residual heat indicators	Bevelled 4 sides
Child lock	Electricity loading 7350W
Red LEDs	

Energy Rating: N/A

Appliance Dimensions (HxWxD) in mm:

44 x 910 x 410

Built-in Dimensions (HxW) in mm:

750 x 490

70cm MaxiSense® Induction Hob

IKE74451FB

KEY FEATURES

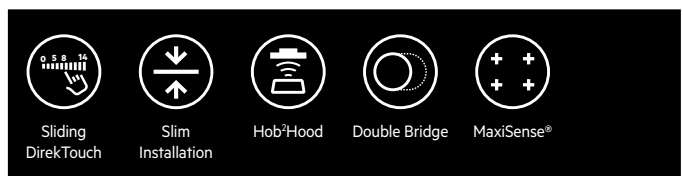

FUNCTIONS

AutoMax	Zone Booster
Count Up Timer	Stop & Go
Minute Minder	Auto Off
Eco Timer	

Additional Features

Residual heat indicators	Bevelled 4 sides
Child lock	Electricity loading 7350W
Red LEDs	

Energy Rating: N/A

Appliance Dimensions (HxWxD) in mm:

44 x 710 x 520

Built-in Dimensions (HxW) in mm:

680 x 490

Also available: IKE74451XB – Steel frame

Dimensions (HxWxD) in mm: 46 x 696 x 516

Built-in Dimensions (HxW) in mm: 680 x 490

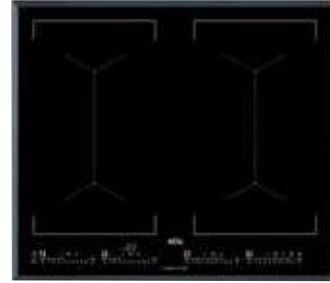

60cm SenseFry® Hob

IAE64850FB

KEY FEATURES



FUNCTIONS

Cook Assist	Stop & Go
Count Up Timer	Auto Off
Minute Minder	Melting
Eco Timer	
Zone Booster	

Additional Features

Residual heat indicators	Bevelled 4 sides
Child lock	Electricity loading 7350W
Red LEDs	

Energy Rating: N/A

Appliance Dimensions (HxWxD) in mm:

44 x 590 x 520

Built-in Dimensions (HxW) in mm:

560 x 490

60cm ActiveTouch Hob

IKE64651FB

KEY FEATURES

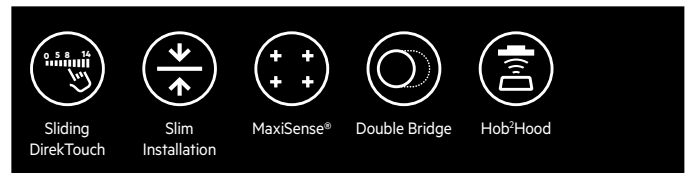

FUNCTIONS

Pot Detection	Stop & Go
Count Up Timer	Auto Off
Minute Minder	
Eco Timer	
Zone Booster	

Additional Features

Residual heat indicators	Bevelled 4 sides
Child lock	Electricity loading 7350W
Red and White LEDs	

Energy Rating: N/A

Appliance Dimensions (HxWxD) in mm:

44 x 590 x 520

Built-in Dimensions (HxW) in mm:

560 x 490

HOBS

INDUCTION HOBS



60cm PURE2 Induction Hob

HKP67420FB

KEY FEATURES



FUNCTIONS

AutoMax	Zone Booster
Count Up Timer	Stop & Go
Minute Minder	Auto Off
Eco Timer	

Additional Features

Residual heat indicators	Red LEDs
Child lock	Electricity loading 7350W

Energy Rating: N/A

Appliance Dimensions (HxWxD) in mm:

55 x 620 x 520

Built-in Dimensions (HxW) in mm:

590 x 490

60cm PURE1 Induction Hob

HK674400FB

KEY FEATURES



FUNCTIONS

AutoMax	Zone Booster
Count Up Timer	Stop & Go
Minute Minder	Auto Off
Eco Timer	

Additional Features

Residual heat indicators	Bevelled 4 sides
Child lock	Electricity loading 7400W
Red LEDs	

Energy Rating: N/A

Appliance Dimensions (HxWxD) in mm:

55 x 590 x 520

Built-in Dimensions (HxW) in mm:

560 x 490

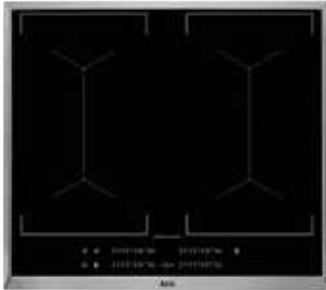

60cm MaxiSense® Induction Hob

IKE64450XB

KEY FEATURES

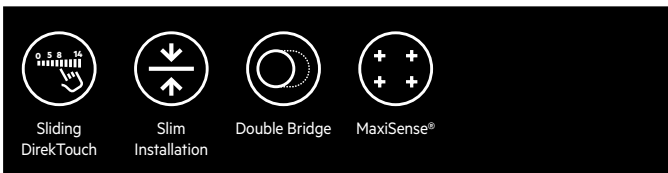

FUNCTIONS

AutoMax	Zone Booster
Count Up Timer	Stop & Go
Minute Minder	Auto Off
Eco Timer	

Additional Features

Residual heat indicators	Steel frame
Child lock	Electricity loading 7350W
Red LEDs	

Energy Rating: N/A

Appliance Dimensions (HxWxD) in mm:

46 x 576 x 516

Built-in Dimensions (HxW) in mm:

560 x 490

Also available: IKE64450FB – Bevelled

Dimensions (HxWxD) in mm: 46 x 590 x 520

Built-in Dimensions (HxW) in mm: 560 x 490

60cm MaxiSense® Induction Hob

IKB64431FB

KEY FEATURES

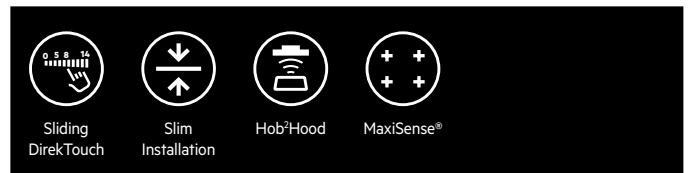

FUNCTIONS

AutoMax	Zone Booster
Count Up Timer	Stop & Go
Minute Minder	Auto Off
Eco Timer	

Additional Features

Residual heat indicators	Bevelled 4 sides
Child lock	Electricity loading 7350W
Red LEDs	

Energy Rating: N/A

Appliance Dimensions (HxWxD) in mm:

44 x 590 x 520

Built-in Dimensions (HxW) in mm:

560 x 490

INDUCTION HOBS



60cm Induction Hob

IKB64401FB

KEY FEATURES

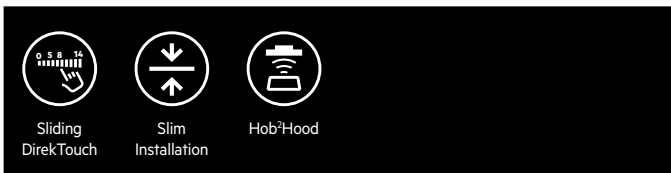

FUNCTIONS

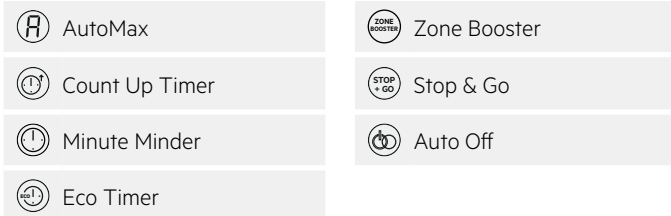

Additional Features

Residual heat indicators Bevelled 4 sides
 Child lock Electricity loading 7350W
 Red LEDs

Energy Rating: N/A

Appliance Dimensions (HxWxD) in mm:

44 x 590 x 520

Built-in Dimensions (HxW) in mm:

560 x 490

Also available: IKB64401XB – Steel frame

Dimensions (HxWxD) in mm: 46 x 576 x 516

Built-in Dimensions (HxW) in mm: 560 x 490

60cm Plug and Play Induction Hob

HK6042001B

KEY FEATURES

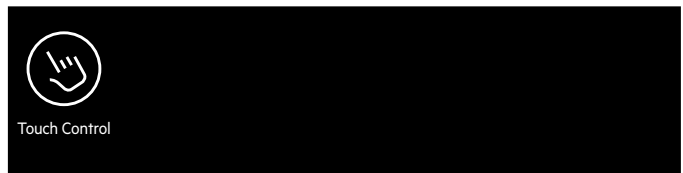

FUNCTIONS



Additional Features

Residual heat indicators Frameless
 Child lock 13 amp plug
 Red LEDs

Energy Rating: N/A

Appliance Dimensions (HxWxD) in mm:

60 x 590 x 520

Built-in Dimensions (HxW) in mm:

560 x 490



90cm MaxiSense® Induction Hob

IKE95471FB

KEY FEATURES

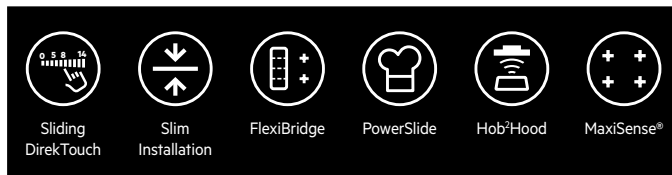

FUNCTIONS

AutoMax	Zone Booster
Count Up Timer	Stop & Go
Minute Minder	Auto Off
Eco Timer	

Additional Features

Residual heat indicators	Bevelled 4 sides
Child lock	Electricity loading 7350W
Red LEDs	

Energy Rating: N/A

Appliance Dimensions (HxWxD) in mm:

44 x 910 x 520

Built-in Dimensions (HxW) in mm:

880 x 490

90cm MaxiSense® Slim Depth Hob

IKK93431FB

KEY FEATURES

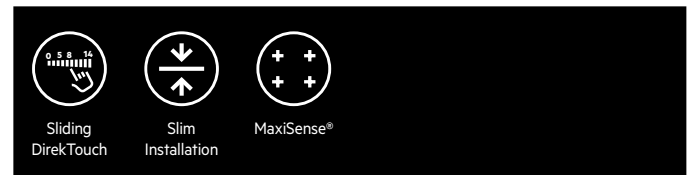

FUNCTIONS

AutoMax	Zone Booster
Count Up Timer	Stop & Go
Minute Minder	Auto Off
Eco Timer	

Additional Features

Residual heat indicators	Bevelled 4 sides
Child lock	Electricity loading 6900W
Red LEDs	

Energy Rating: N/A

Appliance Dimensions (HxWxD) in mm:

44 x 910 x 410

Built-in Dimensions (HxW) in mm:

880 x 380

HOBS

COMBO HOBS



80cm Hob Hood Integrated Hob

IDK84451IB

KEY FEATURES

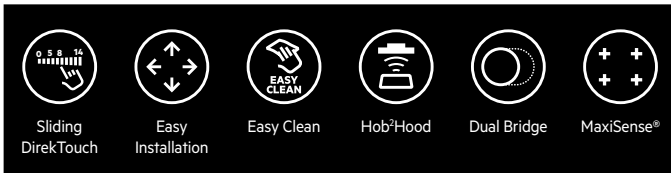

FUNCTIONS

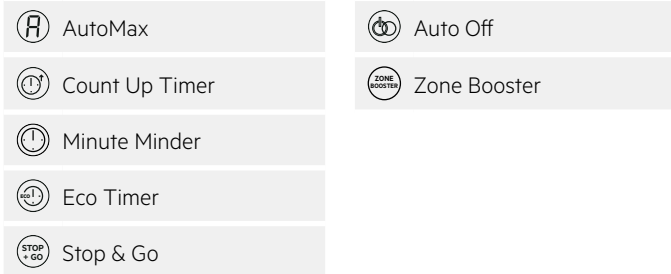

Additional Features

Residual heat indicators	Recirculation max 400 m3/h
Child lock	Recirculation intensive 420 m3/h
Red LEDs	Max noise 71dB(A)
Electricity loading 7400W	

Energy Rating: A+

Appliance Dimensions (HxWxD) in mm:

210 x 830 x 510

Built-in Dimensions (HxW) in mm:

805 x 490

Also available: IDK84452IB – Ducted
 Ducted max 600 m3/h
 Ducted intensive 647 m3/h
 Max noise 68dB(A)

80cm Hob Hood Integrated Hob

IDE84241IB

KEY FEATURES

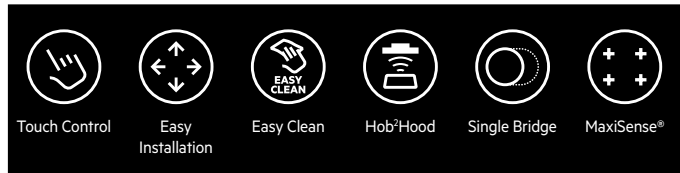

FUNCTIONS

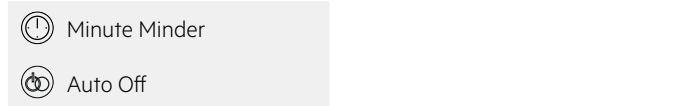

Additional Features

Residual heat indicators	Recirculation max 400 m3/h
Child lock	Recirculation intensive 420 m3/h
Red LEDs	Max noise 71dB(A)
Electricity loading 7400W	

Energy Rating: A+

Appliance Dimensions (HxWxD) in mm:

210 x 830 x 510

Built-in Dimensions (HxW) in mm:

805 x 490

Also available: IDE84242IB – Ducted
 Ducted max 600 m3/h
 Ducted intensive 647 m3/h
 Max noise 68dB(A)

CERAMIC HOBS



60cm Ceramic Hob

HK634060XB

KEY FEATURES



FUNCTIONS

AutoMax	Stop & Go
Count Up Timer	Auto Off
Minute Minder	
Eco Timer	

Additional Features

Residual heat indicators	Steel frame
Child lock	Electricity loading 7000W
Red LEDs	

Energy Rating: N/A

**Appliance Dimensions
(HxWxD) in mm:**

38 x 576 x 516

**Built-in Dimensions
(HxW) in mm:**

560 x 490

GAS COOKING WITH ABSOLUTE ASSURANCE



TouchSure Hob

The advanced TouchSure hob from AEG comes with a range of reassuring safety features that provide absolute confidence in – and absolute command over – gas cooking. It's a traditional method harnessed with our responsive technology. Instilling confidence to turn up the heat.





FlameLight

FlameLight LED indicators tell you if a burner is turned on or off. And residual heat indicators show whether pan supports are still hot after use.



Vertical Flame

The unique design of the Flush Vertical flame burners makes it possible to integrate them into the glass hob top, so you have a smooth hob surface that is stylish, as well as very easy to clean.



Hob²Hood

The AEG Hob²Hood adapts to your cooking to keep your kitchen free of steam and vapours without you even having to touch it.

HOBS

GAS HOBS



90cm Touchsure Gas on Glass Hob

HVB95450IB

KEY FEATURES



FUNCTIONS



Additional Features

Thermocouple
Residual heat indicators
Child lock

Energy Rating: N/A

Appliance Dimensions (HxWxD) in mm:

52 x 880 x 510

Built-in Dimensions (HxW) in mm:

850 x 490

90cm Flamelight Gas on Glass Hob

HKB95540NB

KEY FEATURES

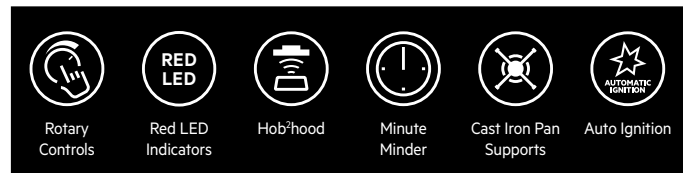

FUNCTIONS



Additional Features

Thermocouple
Residual heat indicators

Energy Rating: N/A

Appliance Dimensions (HxWxD) in mm:

40 x 880 x 510

Built-in Dimensions (HxW) in mm:

830 x 480



90cm Gas Hob with 6 Burners

HG956440SM

KEY FEATURES

- Rotary Controls
- Cast Iron Pan Supports
- Auto Ignition

FUNCTIONS

- Wok Burner
- 2 Aux. Burners
- 2 Semi-rapid Burners
- 1 Rapid Burner

Additional Features

Thermocouple

Energy Rating: N/A

Appliance Dimensions (HxWxD) in mm:

80 x 894 x 510

Built-in Dimensions (HxW) in mm:

830 x 430

75cm Touchsure Gas on Glass Hob

HVB75450IB

KEY FEATURES

- Touch Control
- Hobhood
- Minute Minder
- Stop & Go
- Cast Iron Pan Supports
- Auto Ignition

FUNCTIONS

- Wok Burner
- 1 Aux. Burner
- 3 Semi-rapid Burners

Additional Features

Thermocouple
Residual heat indicators
Child lock

Energy Rating: N/A

Appliance Dimensions (HxWxD) in mm:

52 x 750 x 510

Built-in Dimensions (HxW) in mm:

720 x 490

HOBS

GAS HOBS

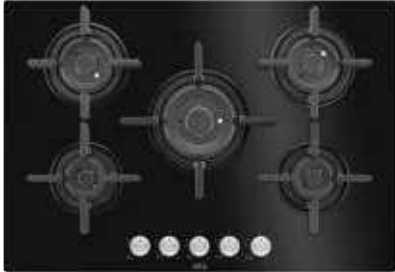

75cm Flush Vertical Flame Gas on Glass Hob

HG795840NB

KEY FEATURES

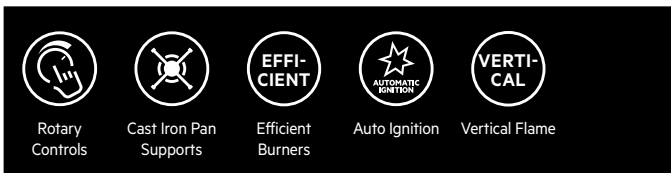

FUNCTIONS

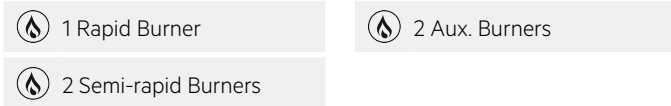

Additional Features

Thermocouple

Energy Rating: N/A

Appliance Dimensions (HxWxD) in mm:

45 x 740 x 510

Built-in Dimensions (HxW) in mm:

560 x 490

75cm Flush Vertical Flame Hob

HG755820UM

KEY FEATURES

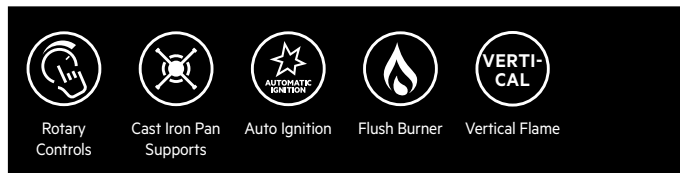

FUNCTIONS



Additional Features

Thermocouple

Energy Rating: N/A

Appliance Dimensions (HxWxD) in mm:

45 x 745 x 515

Built-in Dimensions (HxW) in mm:

560 x 490

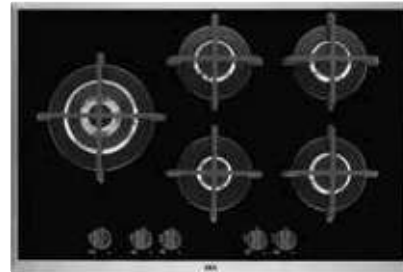

75cm Flamelight Gas on Glass Hob

HKB75540NB

KEY FEATURES

Rotary Controls	Red LED Indicators	Hob Hood	Minute Minder	Cast Iron Pan Supports	Auto Ignition

FUNCTIONS

Wok Burner	1 Aux. Burner
3 Semi-rapid Burners	

Additional Features

Thermocouple
Residual heat indicators

Energy Rating: N/A

Appliance Dimensions (HxWxD) in mm:

40 x 740 x 510

Built-in Dimensions (HxW) in mm:

560 x 480

75cm Semi-Flush Gas on Glass Hob

HG795550XB

KEY FEATURES

Rotary Controls	Cast Iron Pan Supports	Auto Ignition	Efficient Burners

FUNCTIONS

Side Wok Burner	1 Aux. Burner
3 Semi-rapid Burners	

Additional Features

Thermocouple

Energy Rating: N/A

Appliance Dimensions (HxWxD) in mm:

53 x 766 x 516

Built-in Dimensions (HxW) in mm:

750 x 490

HOBS

GAS HOBS



70cm Semi-Flush Gas on Glass Hob

HG795450XB

KEY FEATURES

- Rotary Controls
- Cast Iron Pan Supports
- Auto Ignition
- Efficient Burners

FUNCTIONS

- Wok Burner
- 1 Aux. Burner
- 3 Semi-rapid Burners

Additional Features

Thermocouple

Energy Rating: N/A

Appliance Dimensions (HxWxD) in mm:

53 x 696 x 516

Built-in Dimensions (HxW) in mm:

680 x 490

75cm Ultraflat Hob

HG755421UM

KEY FEATURES

- Rotary Controls
- Cast Iron Pan Supports
- Auto Ignition
- Efficient Burners

FUNCTIONS

- Wok Burner
- 1 Aux. Burner
- 3 Semi-rapid Burners

Additional Features

Thermocouple

Energy Rating: N/A

Appliance Dimensions (HxWxD) in mm:

45 x 745 x 515

Built-in Dimensions (HxW) in mm:

560 x 480

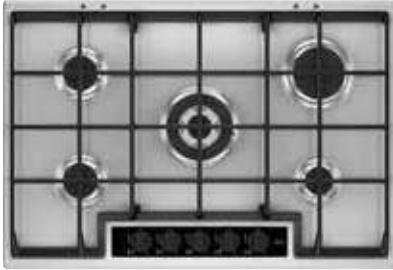

75cm Gas Hob with Central Wok Burner

HG755450SY

KEY FEATURES

Rotary Controls	Cast Iron Pan Supports	Auto Ignition	Efficient Burners

FUNCTIONS

Wok Burner	1 Aux. Burner
2 Semi-rapid Burners	1 Rapid Burner

Additional Features

Thermocouple

Energy Rating: N/A

Appliance Dimensions (HxWxD) in mm:

40 x 744 x 510

Built-in Dimensions (HxW) in mm:

560 x 480

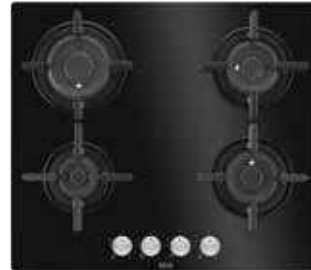

60cm Flush Vertical Flame Gas on Glass Hob

HG694840NB

KEY FEATURES

Rotary Controls	Cast Iron Pan Supports	Gas on Glass	LED Indicators	Auto Ignition	Vertical Flame

FUNCTIONS

1 Rapid Burner	1 Aux. Burner
2 Semi-rapid Burners	Flush Burner

Additional Features

Thermocouple

Energy Rating: N/A

Appliance Dimensions (HxWxD) in mm:

45 x 590 x 520

Built-in Dimensions (HxW) in mm:

560 x 490

HOBS

GAS HOBS



60cm Stainless Vertical Flame Hob

HG654820UM

KEY FEATURES

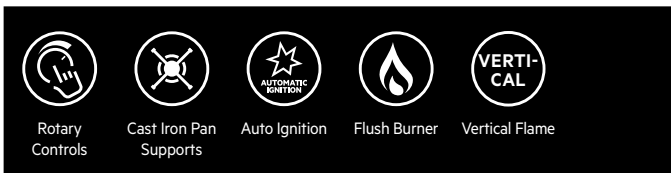

FUNCTIONS



Additional Features

Thermocouple

Energy Rating: N/A

Appliance Dimensions (HxWxD) in mm:

45 x 590 x 520

Built-in Dimensions (HxW) in mm:

560 x 490

60cm Flamelight Gas on Glass Hob

HKB64540NB

KEY FEATURES

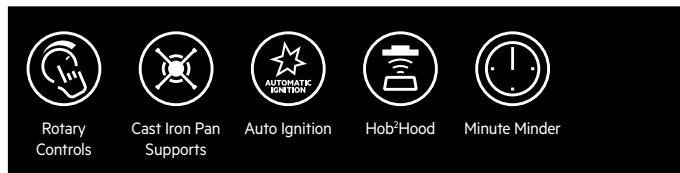

FUNCTIONS



Additional Features

Thermocouple

Residual heat indicators

Energy Rating: N/A

Appliance Dimensions (HxWxD) in mm:

40 x 590 x 520

Built-in Dimensions (HxW) in mm:

560 x 480

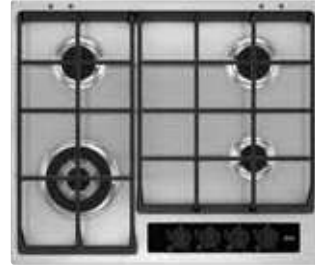
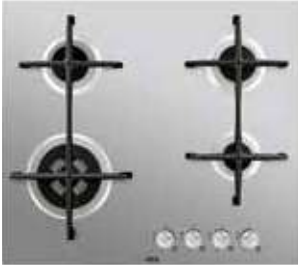

60cm Ultraflat Hob

HG654421UM

KEY FEATURES

Rotary Controls	Cast Iron Pan Supports	Auto Ignition	Efficient Burners

FUNCTIONS

Wok Burner	1 Aux. Burner
2 Semi-rapid Burners	

Additional Features

Thermocouple

Energy Rating: N/A

Appliance Dimensions (HxWxD) in mm:

45 x 595 x 525

Built-in Dimensions (HxW) in mm:

560 x 480

60cm Gas Hob with Wok Burner

HG654550SY

KEY FEATURES

Rotary Controls	Cast Iron Pan Supports	Auto Ignition	Efficient Burners

FUNCTIONS

Wok Burner	1 Aux. Burner
2 Semi-rapid Burners	

Additional Features

Thermocouple

Energy Rating: N/A

Appliance Dimensions (HxWxD) in mm:

40 x 595 x 510

Built-in Dimensions (HxW) in mm:

560 x 495

HOBS

MIXED FUEL HOBS

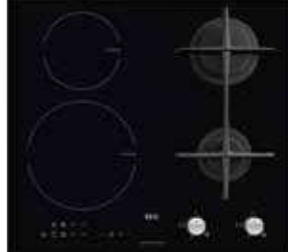
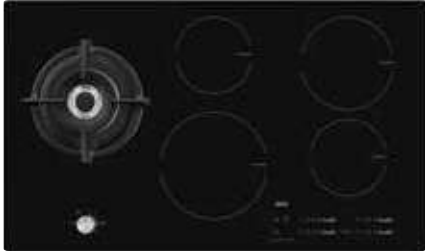

90cm Mixed Fuel Hob

HD955100NB

KEY FEATURES

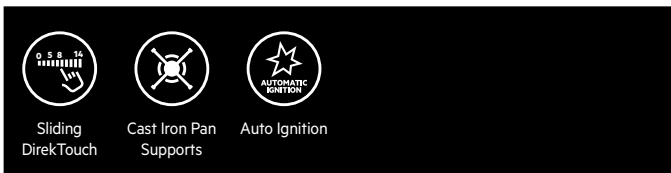

FUNCTIONS



Additional Features

Thermocouple

Energy Rating: N/A

Appliance Dimensions (HxWxD) in mm:

47 x 880 x 520

Built-in Dimensions (HxW) in mm:

830 x 490

60cm Mixed Fuel Hob

HD634170NB

KEY FEATURES

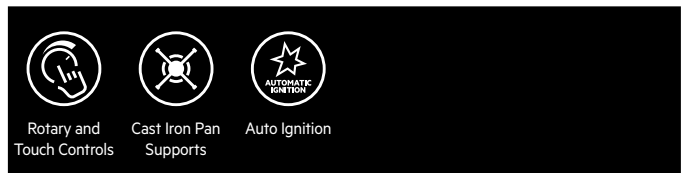

FUNCTIONS



Additional Features

Thermocouple

Energy Rating: N/A

Appliance Dimensions (HxWxD) in mm:

50 x 590 x 520

Built-in Dimensions (HxW) in mm:

560 x 490

CRYSTALLINE HOBS

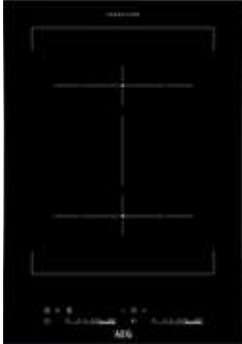

MaxiSense® 2 Zone Induction Hob

HC452401EB

KEY FEATURES

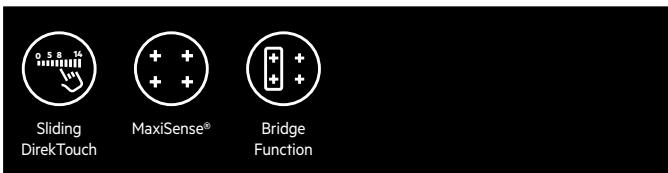

FUNCTIONS

AutoMax	Zone Booster
Count Up Timer	Stop & Go
Minute Minder	Auto Off
Eco Timer	

Additional Features

Residual heat indicators	Red LEDs
Child lock	Electricity loading 3700W

Energy Rating: N/A

Appliance Dimensions (HxWxD) in mm:

55 x 360 x 520

Built-in Dimensions (HxW) in mm:

340 x 490



Teppanyaki with DirekTouch

HC452601EB

KEY FEATURES

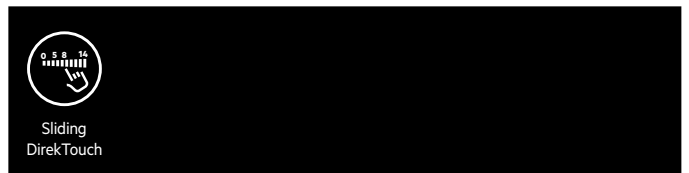

FUNCTIONS

Count Up Timer	Zone Booster
Minute Minder	Auto Off
Eco Timer	

Additional Features

Residual heat indicators	Red LEDs
Child lock	Electricity loading 3200W

Energy Rating: N/A

Appliance Dimensions (HxWxD) in mm:

125 x 360 x 520

Built-in Dimensions (HxW) in mm:

340 x 490

HOBS

CRYSTALLINE HOBS



Induction Hob with Compatible Wok

HC451501EB

KEY FEATURES

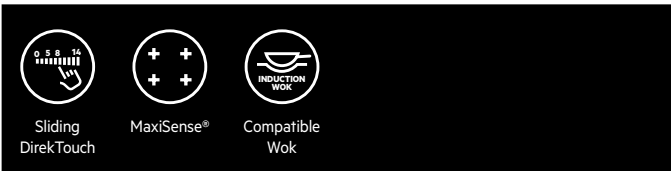

FUNCTIONS

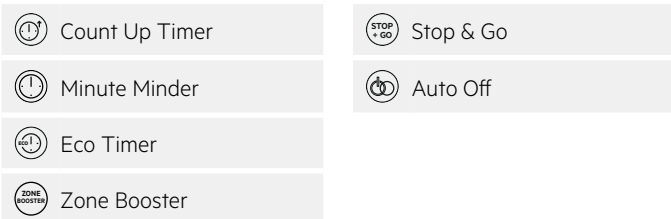

Additional Features

Residual heat indicators Red LEDs
 Child lock Electricity loading 3200W

Energy Rating: N/A

Appliance Dimensions (HxWxD) in mm:

55 x 360 x 520

Built-in Dimensions (HxW) in mm:

340 x 490



Double Gas Hob

HC412001GB

KEY FEATURES

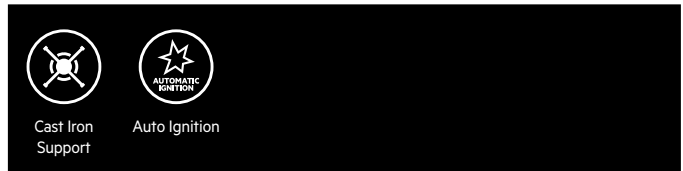

FUNCTIONS



Additional Features

Thermocouple

Energy Rating: N/A

Appliance Dimensions (HxWxD) in mm:

60 x 360 x 520

Built-in Dimensions (HxW) in mm:

340 x 490



Gas Wok Burner

HC411521GB

KEY FEATURES

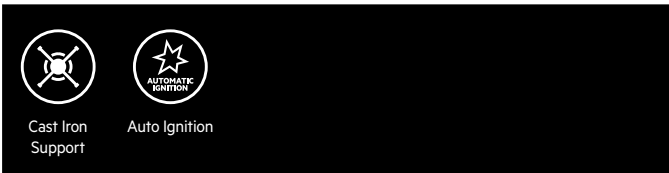

FUNCTIONS

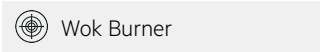

Additional Features

Thermocouple

Energy Rating: N/A

Appliance Dimensions (HxWxD) in mm:

60 x 360 x 520

Built-in Dimensions (HxW) in mm:

340 x 490



Ceramic Hob with DirekTouch

HC452021EB

KEY FEATURES

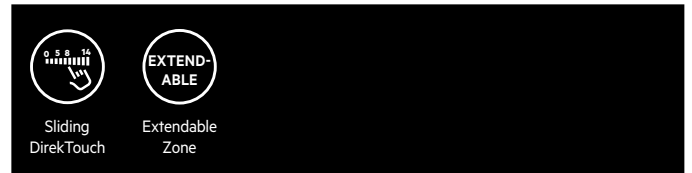

FUNCTIONS



Additional Features

Residual heat indicators

Red LEDs

Child lock

Electricity loading 3500W

Energy Rating: N/A

Appliance Dimensions (HxWxD) in mm:

38 x 360 x 520

Built-in Dimensions (HxW) in mm:

340 x 490

HOODS

Our cooking environments need to be fresh, bright and peaceful, enriching the time that we spend there. We use advanced technology to ensure that the design and build of our cooker hoods give you the optimum combination of high-end design and powerful functionality.



LED LIGHTING



BREEZE FUNCTION



SILENCETECH



HOB²HOOD

A FRESHER KITCHEN, HANDS FREE



Hob²Hood

The AEG Hob²Hood adapts to your cooking to keep your kitchen free of steam and vapours without you even having to touch it.

As you cook, the hood activates automatically, monitoring the fluctuating heat and steam of every simmer and boil, effortlessly maintaining the freshness of your kitchen. Your attention stays, as it should, on preparing, finessing and enjoying your dish.





LED Lighting

Provides the possibility to adjust the intensity of the light according to your needs, creating the perfect ambient illumination in your kitchen.



Breeze Function

The breeze function quietly refreshes the air in your kitchen to create a more enjoyable atmosphere to relax or entertain.

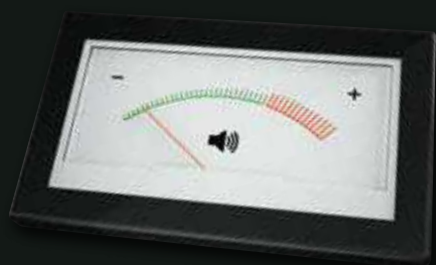

SilenceTech

Our more advanced hood technology reduces the noise level down to the lowest number of decibels so that you can cook powerfully and enjoy the experience without loud sounds from the appliance.

A GUIDE TO HOODS ICONS

KEY FEATURES



Hob²Hood

A wireless function that when paired with suitable hobs, it automatically activates and regulates the cooker hood according to your cooking activities. Providing a fresher kitchen environment so you can focus on achieving great taste.



Touch on Glass Controls

Smooth and precise control of all your hood's functions with a simple touch on glass – easy to use and easy to clean.



Push Button Controls

Precise control of the setting levels allowed through the squared push buttons.



Designer Filter Cover

High filter efficiency combined with perfect stainless steel designed filter covers – the perfect look and easy to clean in the dishwasher.



LED Strip Lighting

LED strip lighting enables an excellent visibility on the entire cooking process and provide ambient lighting in the kitchen.



Dimmable LED Lighting

Crisp bright illumination, or a gentle glow? Dimmer-controlled LED lighting means you can adjust the effect at the touch of a fingertip.



Black Glass

Beautiful design with unique black glass.



Stainless Steel

The anti fingerprint stainless steel finishing protects the surface of your cooker hood from fingerprints.



Stainless Steel with Glass

Perfect combination of stainless steel and glass to create a unique and professional style in your kitchen environment.

FUNCTIONS



Fan Speeds

Number of fan speeds, allowing you to adjust the power, noise and energy consumption.



SilenceTech

Reduces the noise level down to our lowest number of decibels so that you can cook powerfully and enjoy all your favourite food without annoying sounds from the appliance.



Breeze Function

Refreshes the air in your kitchen after cooking at a very low noise level so that you have a more enjoyable and quiet atmosphere to relax or entertain.



Remote Control Included

Easy and fast control of all the hood's functions thanks to the remote control.



Extendable to 80cm

An innovative addition that allows you to expand your hood from 60 cm to 80 cm.

HOODS

Aligned across our range, your choice of hood will integrate seamlessly with any of our hob models. Our top line models feature our signature flow line for design harmony, together with a sophisticated white LED display on layered glass and metal.



100cm Island Hood
DIK7190HG

KEY FEATURES

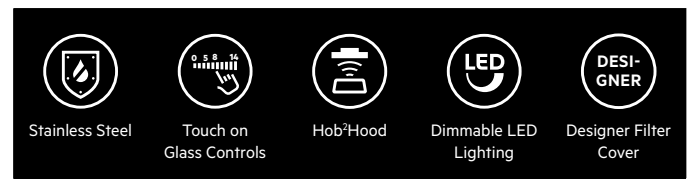

FUNCTIONS



Additional Features

Charcoal filter included

Noise: 71dB – 36dB

Motor speed: 801 m³/h

Energy Rating: A++

Dimensions (HxWxD) in mm: (967–747) 75 x 1000 x 700

HOODS



90cm Downdraft Hood
DDE5980G

120cm Ceiling Hood
DCK6290HG

KEY FEATURES

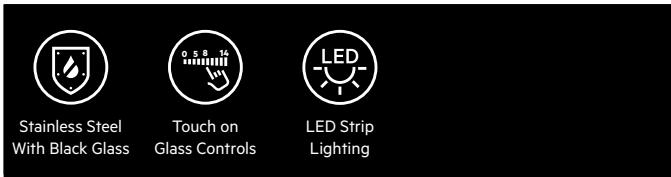

KEY FEATURES

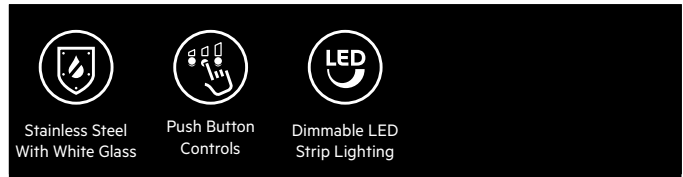

FUNCTIONS



FUNCTIONS

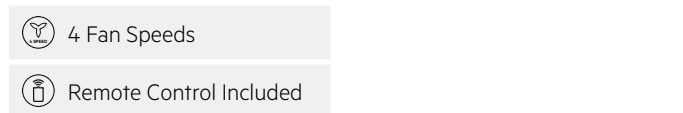

Additional Features

Charcoal filter included Noise: 70dB – 40dB
Motor speed: 700 m³/h

Additional Features

Charcoal filter included Noise: 70dB – 45dB
Motor speed: 870 m³/h

Energy Rating: A

Dimensions (HxWxD) in mm: 407 x 880 x 95

Energy Rating: A+

Dimensions (HxWxD) in mm: 311 x 1199 x 499



90cm / 60cm Designer Screen Hood
DVK6980HB / DVK6680HB

KEY FEATURES

- Stainless Steel with Black Glass
- Touch on Glass Controls
- Hob²Hood
- Dimmable LED Lighting

FUNCTIONS

- 5 Fan Speeds
- SilenceTech
- Breeze Function

Additional Features

Charcoal filter included Noise: 68dB – 52dB
Motor speed: 720 m³/h

Energy Rating: A+

Dimensions (HxWxD) in mm:

DVK6980HB 90cm – (1445–1095) 465 x 898 x 396
DVK6680HB 60cm – (1445–1095) 465 x 598 x 396

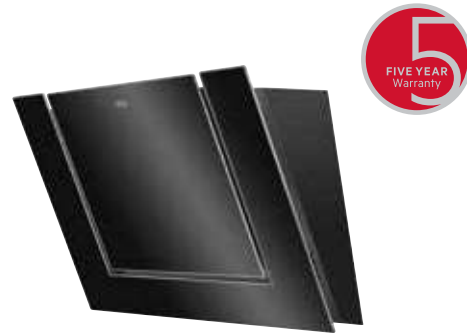

80cm Designer Screen Hood
DVB4850B

KEY FEATURES

- Black Glass
- Push Button Controls
- LED Spotlights

FUNCTIONS

- 3 Fan Speeds

Additional Features

Charcoal filter included Noise: 67dB
Motor speed: 647 m³/h

Energy Rating: B

Dimensions (HxWxD) in mm:



DVB4850B 80cm – 477 x 800 x 335

HOODS



80cm Designer Screen Hood
DVB4850M

KEY FEATURES

- 
Stainless Steel
- 
Push Button Controls
- 
LED Spotlights

FUNCTIONS

-  3 Fan Speeds

Additional Features

Charcoal filter included Noise: 67dB
Motor speed: 647 m³/h





Energy Rating: B

Dimensions (HxWxD) in mm:
DVB4850M 80cm – 477 x 800 x 335



90cm T Shape Chimney Hood
DBK7990HG

KEY FEATURES

- 
Stainless Steel
- 
Touch on Glass Controls
- 
Hob²Hood
- 
Dimmable LED Strip Lighting

FUNCTIONS

-  Remote Control Included
-  Breeze Function
-  5 Fan Speeds
-  SilenceTech

Additional Features

Charcoal filter included Noise: 70dB – 36dB
Motor speed: 801 m³/h

Energy Rating: A++

Dimensions (HxWxD) in mm: (1165–725) 75 x 898 x 550



90cm / 70cm / 60cm T Shape Chimney Hood
DBE6980HM / DBE6780HM / DBE6680HM

KEY FEATURES

- Stainless Steel
- Touch on Glass Controls
- Hob²Hood
- Dimmable LED Strip Lighting

FUNCTIONS

- 5 Fan Speeds
- SilenceTech
- Breeze Function

Additional Features

Charcoal filter included Noise: 71dB – 52dB
Motor speed: 710 m³/h

Energy Rating: A+

Dimensions (HxWxD) in mm:

DBE6980HM 90cm – (890–740) 60 x 898 x 470
DBE6780HM 70cm – (890–740) 60 x 698 x 470
DBE6680HM 60cm – (890–740) 60 x 598 x 470



90cm / 60cm Chimney Hood
DKB4950M / DKB4650M

KEY FEATURES

- Stainless Steel
- Push Button Controls
- LED Lighting

FUNCTIONS

- 3 Fan Speeds

Additional Features

Charcoal filter TYPE20 (accessory) Noise: 69dB – 46dB
Motor speed: 603 m³/h

Energy Rating: B

Dimensions (HxWxD) in mm:

DKB4950M 90cm – (1090–665) 40 x 898 x 500
DKB4650M 60cm – (1090–665) 40 x 598 x 500

HOODS



60cm Pull Out Hood
DPB3631S

70cm Canopy Hood
DGB3850M

KEY FEATURES

- Silver
- Push Button Controls
- LED Lighting

KEY FEATURES

- Stainless Steel
- Push Button Controls
- LED Lighting

FUNCTIONS

- 3 Fan Speeds

FUNCTIONS

- 4 Fan Speeds

Additional Features

Charcoal filter included Noise: 68dB – 48dB
Motor speed: 370 m3/h

Additional Features

Charcoal filter included Noise: 63dB – 49dB
Motor speed: 600 m3/h

Energy Rating: C

Dimensions (HxWxD) in mm:
DPB3631S 60cm – (179) 40 x 598 x 284

Energy Rating: C

Dimensions (HxWxD) in mm: 245 x 700 x 285



60cm Integrated Hood
DEB2631S

KEY FEATURES

SILVER
Silver

Slider Control

LED
LED Lighting

FUNCTIONS

2 Fan Speeds

Additional Features

Charcoal filter included Noise: 62dB – 47dB
Motor speed: 352 m3/h

Energy Rating: D

Dimensions (HxWxD) in mm: 400 x 598 x 270

DISHWASHERS

It's not just about the food – the style of cutlery and plates affect our perceptions of what we eat. A dark chocolate dish looks best when served on an angular plate, while a round plate is better for cheesecake. So you need a range of tableware that complements your food presentation and can be cared for in the most efficient way.

IN THIS SECTION

Fully Integrated Dishwashers	125–128
Semi-Integrated Dishwashers	129
Slimline Built-In Dishwashers	129



COMFORTLIFT®



AIRDRY TECHNOLOGY



LIFTS GENTLE TO A NEW LEVEL



ComfortLift®

The ComfortLift® dishwasher is the first of its kind to gently slide the lower basket up for easy, ergonomic loading and unloading. That means less bending down, to make your life more comfortable.





AirDry Technology

Uses natural airflow to finish the drying. By automatically opening the door by 10cm in the last part of the cycle, you will get maximum drying performance while effectively reducing your energy costs – leaving your dishes spotless.



XXL Interiors

The XXL interior of this dishwasher gives you an additional 10 litres of space, more capacity for those irregular shaped items.



Removable Cutlery Tray

Take your tray with you to the kitchen cutlery drawer for easy unloading. Best in class solutions for easy loading and unloading.

SUPERIOR CLEANING AND FULL COVERAGE



ProClean

The multiple double rotation of the Satellite Spray Arm sprays from continuously varying angles, leaving your dishes and cookware gleaming.

5 Spray levels

Multi level spray reaches every item anywhere, giving you our most efficient spray coverage.

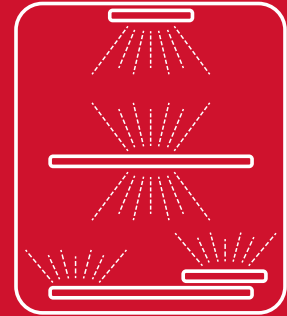

Standard spray arm coverage

versus



Satellite spray arm coverage



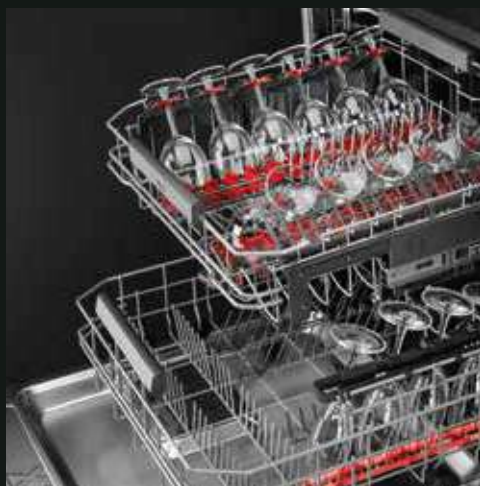

Glass Care Programme

Special 45°C glass programme ensures perfect washing results while protecting your most precious glass, crystal and china.



Delay Time

Allows you to select when the machine should start.

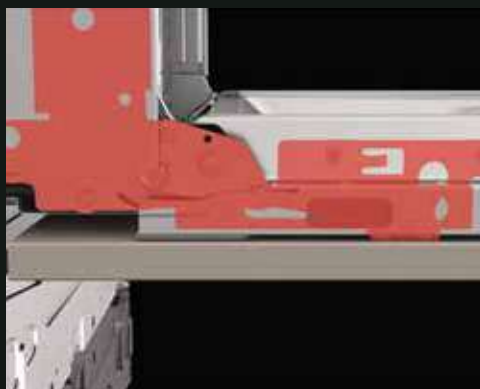

Sliding Hinges

Allows you to install the dishwasher with any door length without the need to cut the kitchen plinth. This is also suitable for plinthless kitchens. The best solution on the market – patented by AEG.

A GUIDE TO DISHWASHER ICONS

KEY FEATURES



ComfortLift®

The ComfortLift® basket rises on special hinges, ensuring less bending when loading and unloading dishes.



GlassCare Package

Delicate wine glasses are protected with our soft spikes, soft grips and dedicated GlassCare 45°C programme.



Removable Cutlery Drawer

Take your tray with you to the kitchen cutlery drawer for easy unloading. Best in class solutions for easy loading and unloading.



TimeBeam

Keeps you informed on the progress of the programme by projecting the remaining time on the floor.



InteriorLight

Locate items at a glance thanks to the bright internal light.



ProClean

Our ProClean models have a larger usable internal space, combined with five spray levels, satellite and ceiling spray arm plus GlassCare package.



XXL Interior

The XXL interior of this dishwasher gives you an additional 10 litres of space, more capacity for those irregular shaped items and plates up to 33cm in diameter.



TimeSaver Function

50% less time thanks to increased power speed and water pressure.



24 Hour Time Delay

Run your dishwasher when it suits you, thanks to the up to 24 hour delay start function.



Light Beam

This dishwasher is so quiet it projects a tiny red or green beam on to the floor to tell you when it's running and when it's finished.



AirDry

Uses natural airflow to finish the drying. By automatically opening the door by 10cm in the last part of the cycle, you will get maximum drying performance leaving your dishes spotless.



Sliding Hinge

With this dishwasher you can choose to install it normally above a plinth, or as it has a sliding hinge, it is perfect for plinthless kitchens or for installation above a small cupboard.



Double Fulcrum Hinge

For ease of installation, this hinge on this model rises over the plinth level when the door is opened, so no need to cut the plinth.



Deluxe Interior

Selected models have a higher level of internal finish, including stainless steel drawer handles and knife supports in the cutlery drawer.



FlexiSpray

The combination of four spray levels and lower satellite spray arm ensures superior cleaning levels.

DISHWASHERS

The AEG range of dishwashers is designed to meet the frustrations and needs of dishwasher users. The models are designed to give a better quality wash and superb drying results, combined with a larger capacity and useful features such as our glasscare package which looks after your best wine glasses.

BUILT-IN DISHWASHERS



Fully Integrated ComfortLift® Dishwasher with ComfortRails and Internal Light

FSK93800P

KEY FEATURES

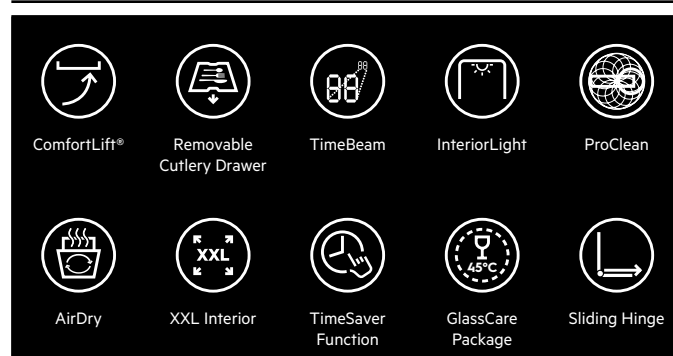

PROGRAMMES – 8

Auto 45°–70°	ProZone 50°–65°
Glass 45°	Extra Silent 50°
Eco	Rinse & Hold
Intensive 70°	
30min 60°	

Additional Features

Auto load adjust: Sensor logic	Flexible basket
24 hour delay	XtraDry
Glass care	Soft grips
Soft spikes	Anti-flood protection

Place Settings: 13
Noise Level: 39dB
Energy Rating: A+++

Water Usage: 11
Appliance Dimensions (HxWxD) in mm:
 818 x 596 x 550

ComfortLift®

The AEG ComfortLift® dishwasher is equipped with a special lower rack lifting mechanism, ensuring less bending when unloading the dishes to make your life more comfortable.



DISHWASHERS

BUILT-IN DISHWASHERS



Fully Integrated 15 Place Setting Dishwasher with Superior Cleaning and Drying

FSK83700P

KEY FEATURES

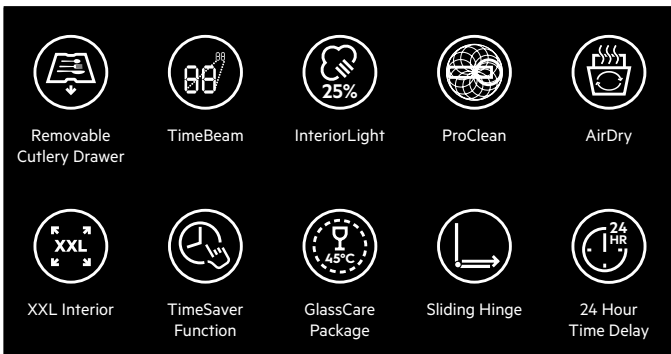

PROGRAMMES – 8

Auto 45°–70°	ProZone 50°–65°
Glass 45°	Extra Silent 50°
Eco	Rinse & Hold
Intensive 70°	
30min 60°	

Additional Features

Auto load adjust: Sensor logic	Flexible basket
Auto off	XtraDry
Glass care	Soft grips
Soft spikes	Anti-flood protection

Place Settings: 15
Noise Level: 42dB
Energy Rating: A+++

Water Usage: 11
Appliance Dimensions (HxWxD) in mm:
 818 x 596 x 550



Fully Integrated ComfortLift® Dishwasher

FSK63800P

KEY FEATURES

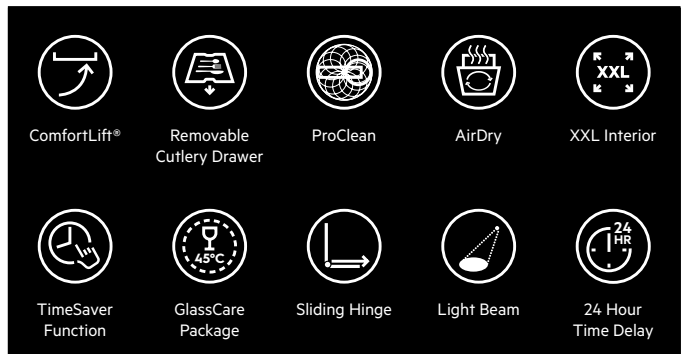

PROGRAMMES – 6

Auto 45°–70°	Extra Silent 50°
Glass 45°	
Eco	
Intensive 70°	
30min 60°	

Additional Features

Auto load adjust: Sensor logic	Flexible basket
Auto off	XtraDry
Glass care	Soft grips
Soft spikes	Anti-flood protection

Place Settings: 13
Noise Level: 44dB
Energy Rating: A+++

Water Usage: 11
Appliance Dimensions (HxWxD) in mm:
 818 x 596 x 550



Fully Integrated ProClean 15 Place Setting Dishwasher with Superior Cleaning and Drying

FSK63700P

KEY FEATURES

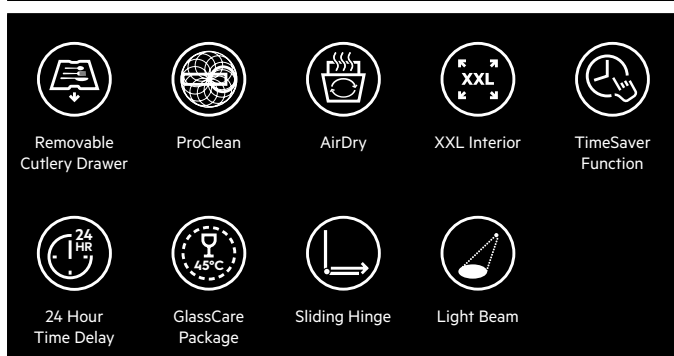

PROGRAMMES – 6

Auto 45°–70°	Extra Silent 50°
Glass 45°	
Eco	
Intensive 70°	
30min 60°	

Additional Features

Auto load adjust: Sensor logic	Flexible basket
Auto off	XtraDry
Glass care	Soft grips
Soft spikes	Anti-flood protection

Place Settings: 15
Noise Level: 44dB
Energy Rating: A+++

Water Usage: 11
Appliance Dimensions (HxWxD) in mm: 818 x 596 x 550



Fully Integrated ProClean Dishwasher with TimeSaver Technology

FSK5260PP

KEY FEATURES

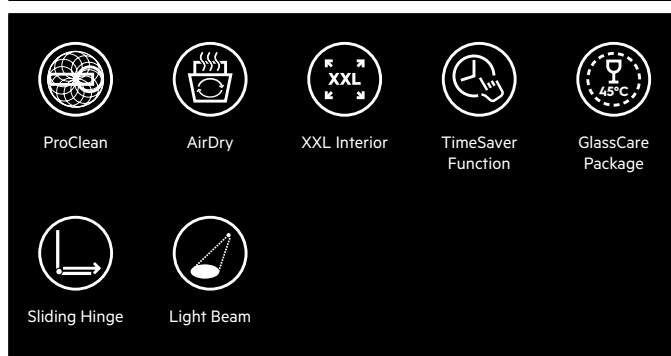

PROGRAMMES – 5

Auto 45°–70°
Glass 45°
Eco
Intensive 70°
30min 60°

Additional Features

Auto load adjust: Sensor logic	Flexible basket
Auto off	XtraDry
Glass care	Soft grips
Soft spikes	Anti-flood protection

Place Settings: 13
Noise Level: 46dB
Energy Rating: A++

Water Usage: 10.5
Appliance Dimensions (HxWxD) in mm: 818 x 596 x 550

DISHWASHERS

BUILT-IN DISHWASHERS



Fully Integrated Dishwasher with TimeSaver Technology

FSK53600Z

KEY FEATURES

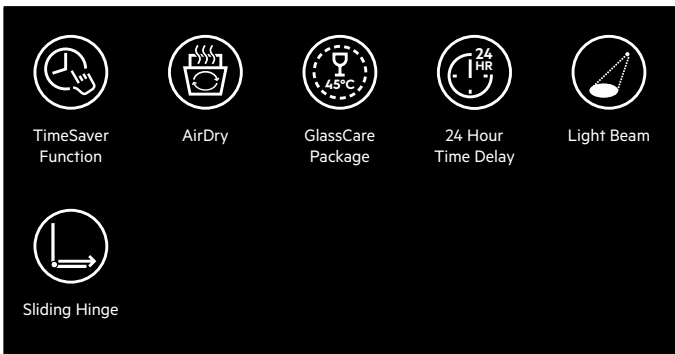

Fully Integrated Dishwasher with AirDry Technology

FSB41600Z

KEY FEATURES

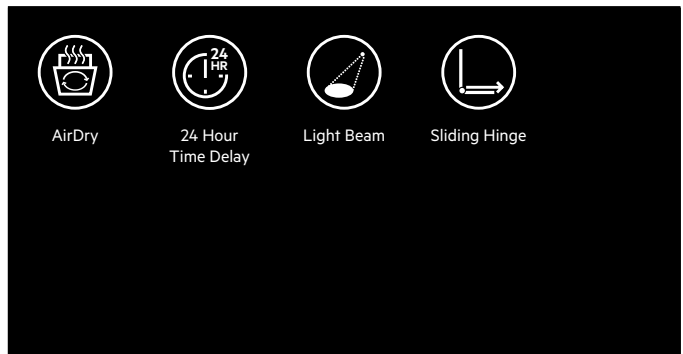

PROGRAMMES - 5

Auto 45°-70°
Glass 45°
Eco
Intensive 70°
30min 60°

Additional Features

Auto load adjust: Sensor logic	Flexible basket
Auto off	XtraDry
Glass care	Anti-flood protection
Soft spikes	

Place Settings: 13
Noise Level: 44dB
Energy Rating: A+++

Water Usage: 9.9
Appliance Dimensions (HxWxD) in mm:
 818 x 596 x 550

PROGRAMMES - 4

Auto 45°-70°
Eco
Intensive 70°
30min 60°

Additional Features

Auto load adjust: Sensor logic	Anti-flood protection
Auto off	
Flexible basket	
XtraDry	

Place Settings: 13
Noise Level: 47dB
Energy Rating: A+

Water Usage: 11
Appliance Dimensions (HxWxD) in mm:
 818 x 596 x 550

SEMI-INTEGRATED BUILT-IN DISHWASHERS



Semi-Integrated Dishwasher with Superior Cleaning and Drying

FEE62600PM

KEY FEATURES



PROGRAMMES – 6

Auto 45°–70°	Extra silent 50°
Glass 45°	
Eco	
Intensive 70°	
30min 60°	

Additional Features

Auto load adjust: Sensor logic	Flexible basket
Auto off	XtraDry
Glass care	Soft grips
Soft spikes	Anti-flood protection

Place Settings: 13
Noise Level: 47dB
Energy Rating: A++

Water Usage: 10.5
Appliance Dimensions (HxWxD) in mm: 818 x 596 x 550

SLIMLINE BUILT-IN DISHWASHERS



Fully Integrated Slimline Dishwasher with Superior Cleaning and Drying

FSK73400P

KEY FEATURES

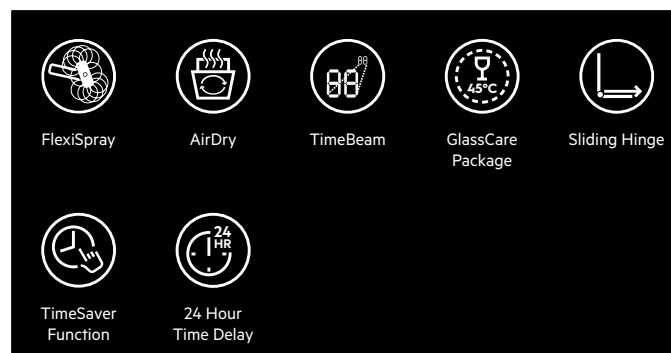

PROGRAMMES – 7

Auto 45°–70°	ProZone 50°–65°
Glass 45°	Extra Silent 50°
Eco	
Intensive 70°	
30min 60°	

Additional Features

Auto load adjust: Sensor logic	Flexible basket
Auto off	XtraDry
Glass care	Anti-flood protection
Soft spikes	

Place Settings: 9
Noise Level: 44dB
Energy Rating: A+++

Water Usage: 9.9
Appliance Dimensions (HxWxD) in mm: 818 x 446 x 550

LAUNDRY

Imagine putting your precious sweater in the washer. Imagine trusting a dryer with a silk dress.

We've not only imagined it, we've done it. Washed the black dress time after time. Dried a soft wool sweater over and over. Every time they emerge without shrinking or fading, still vibrant and soft. Because AEG has redefined what a washer and dryer are. Protectors of fabric. Defenders of colour. Guardians of fibres.

Unprecedented care for the life of your clothes. Imagine that.

IN THIS SECTION

Washing Machines	134–141
Tumble Dryers	142–145
Washer Dryers	146–149



DESIGNED WITH CARE

Our unique, innovative design is more than a pretty face. It also conveys superior quality and technical advancement. For our new range, we increased the size of the door and porthole for ease of use and a modern look, and reinvented the control panel.





Premium Design

Inspired by the electric turbines manufactured at the AEG Turbine Factory in Berlin.

The positioning of the door handle at 2 o'clock makes it easy to open.



Easy to Use Control Panel

A simplified programme choice with only your 10 favourite and most often used programmes.



Complementary Design





AEG Tumble dryers are designed to complement our washing machines and are available with stacking kits.

OUR WASHING MACHINE RANGE

Our washing machine range is structured into 3 series levels. As you go up the series levels, our washing machines step up in the level of fabric care, and include all the technologies from the series below.





	7000 SERIES	8000 SERIES	9000 SERIES
 SoftWater Technology			<input checked="" type="checkbox"/>
 ÖKOMix Technology		<input checked="" type="checkbox"/>	<input checked="" type="checkbox"/>
 ProSteam® Technology	<input checked="" type="checkbox"/>	<input checked="" type="checkbox"/>	<input checked="" type="checkbox"/>
 ProSense® Technology	<input checked="" type="checkbox"/>	<input checked="" type="checkbox"/>	<input checked="" type="checkbox"/>

NO FADING, WASH AFTER WASH*



SoftWater Technology

Thanks to its SoftWater technology, the 9000 series AEG washing machine is kinder to your clothes, keeping fabrics feeling soft and in-shape whilst also preserving colours and preventing fading.

All mains water contains minerals that can be harsh on fabrics. These AEG washing machines are the first in the world with SoftWater Technology to remove these impurities.

Available on 9000 series washing machines.

*Even after 50 washes, colours will keep their intensity and black won't fade to grey. Test for colourfastness performed on black polyester after 50 washing cycles at 30°C.





The blue colour visualises the distribution of fabric softener on the garment.



ÖKOMix Technology

Unique pre-mixing of detergent, softener and water to reach every fibre.

Standard cottons programme without Plus Steam.

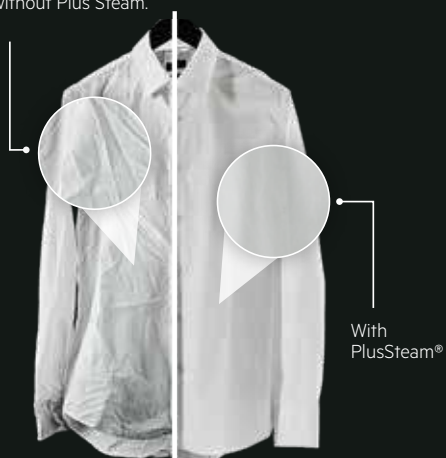

ProSteam® Technology

Using the PlusSteam® option to end a washing cycle with steam, reduces creasing by up to 30%. You can also refresh clothes with a separate steam programme to remove unwanted odours from garments.

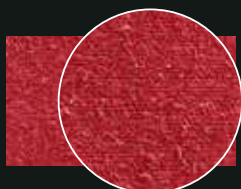

Competitor
Fibres show more wear and tear due to unnecessary over-washing.



6000 Series with ProSense®
An optimised wash cycle results in less over-washing and less wear and tear.



ProSense® Technology

Adjusts time, water and energy consumption to the size of the load, even if it is just a single shirt or your entire weekly wash. This is thanks to specific sensors that will intelligently control the cycle settings and take care that your clothes are only washed for the exact amount of time needed.

WASHING MACHINES

While conventional washing machines need high temperatures to activate detergents and clean properly, the SoftWater Technology in AEG 9000 Series washing machines purifies and softens water before it enters the drum.

9000 SERIES



9000 Series Washing Machine
L9FEC946R

TECHNOLOGY

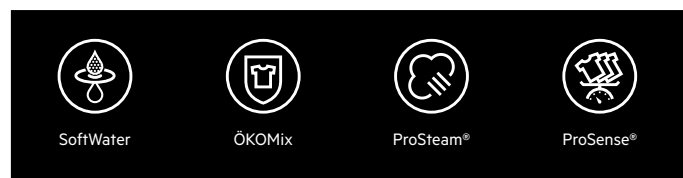

Specifications

Drum: 9kg	Energy rating: A+++
Speed: 1400rpm	

Programmes

Cottons	Steam
Synthetics	ÖKOPower
ColourPro	Anti-Allergy
Delicates	Quick 20min 3kg
Wool/Silk	Outdoor

Additional Features

Soft Plus	Start/Pause
PlusSteam®	Stains/Prewash
Time save	Rinse
Delay start	Extra rinse
Temperature selection	Economy
Spin selection	Child lock

Colour: Stainless steel fascia panel

Appliance Dimensions (HxWxD) in mm: 850 x 600 x 660

Softer water, kinder to clothes

Because our advanced SoftWater Technology purifies and softens water before it enters the drum, detergents can work much more effectively at low temperatures, delivering 60°C cleaning performance at only 30°C. So colours will keep their intensity wash after wash, and black won't fade to grey.



8000 SERIES



8000 Series Washing Machine
L8FEC866R

7000 SERIES



7000 Series Washing Machine
L7FEE845R

TECHNOLOGY

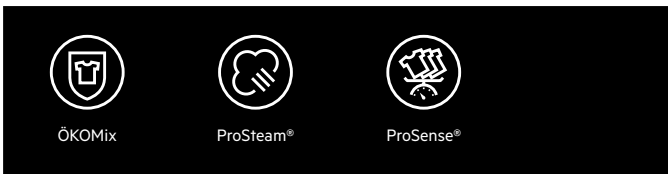

TECHNOLOGY



Specifications

Drum: 8kg	Energy rating: A+++
Speed: 1600rpm	

Specifications

Drum: 8kg	Energy rating: A+++
Speed: 1400rpm	

Programmes

Cottons	ÖKOPower
Synthetics	Anti-Allergy
Delicates	Quick 20min 3kg
Wool/Silk	Outdoor
Steam	Duvet

Programmes

Cottons	Anti-Allergy
Synthetics	Quick 20min 3kg
Delicates	Outdoor
Wool/Silk	Duvet
Steam	Sport

Additional Features

Soft Plus	Start/Pause
PlusSteam®	Stains/Prewash
Time save	Rinse
Delay start	Extra rinse
Temperature selection	Economy
Spin selection	Child lock

Additional Features

Soft Plus	Start/Pause
PlusSteam®	Stains/Prewash
Time save	Rinse
Delay start	Extra rinse
Temperature selection	Economy
Spin selection	Child lock

Colour: Stainless steel fascia panel

Colour: Silver fascia panel

Appliance Dimensions (HxWxD) in mm: 850 x 600 x 660

Appliance Dimensions (HxWxD) in mm: 850 x 600 x 660

WASHING MACHINES



Built-In Washing Machine

L7FC8432BI – Available from September 2018

TECHNOLOGY

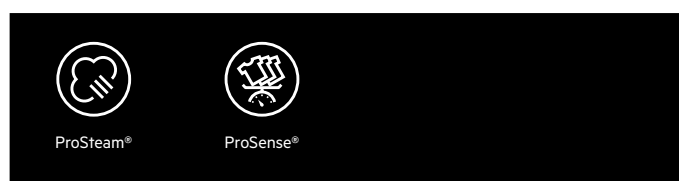

Specifications

Drum: 8kg	Energy rating: A+++
Speed: 1400rpm	

Programmes

Cottons	Wool/Silk
Cotton Eco	Denim
Synthetics	Sport
Delicates	Quick 20min 3kg
Outdoor	Duvet
Steam	Anti-Allergy
Spin/Drain	Rinse

Additional Features

Soft Plus	Stains/Prewash
PlusSteam®	Extra Rinse
Time save	Delay start
Temperature selection	Start/Pause
Spin selection	Child lock

Colour: White fascia panel

Appliance Dimensions (HxWxD) in mm: 820 x 596 x 555

Tips

Fully integrated machine to fit seamlessly into your kitchen.

AWARD WINNING QUALITY



Woolmark

The Woolmark Apparel Care programme helps consumers identify quality laundry appliances that are approved by The Woolmark Company for use on woollen fabrics.

Woolmark Blue

It is the Woolmark Apparel Care certification of wool cycles that identifies a machine as safe in which to wash handwash only woollen fabrics.

Woolmark Green

The gentleness required is exactly the same as for Woolmark Blue, but the programme uses less energy and water, hence the symbolic green labelling.



Ariel and Lenor certified

Our washing machine range is certified by Ariel and Lenor for their efficient use of liquid detergent and fabric softener. Any machine with ÖKOMix technology has received the premium certification by Ariel and Lenor. The certification guarantees that 90% of fabrics in a washing load are evenly covered with liquid fabric softener. AEG, Ariel and Lenor have partnered to provide you with their combined unique care expertise for fabrics.



Quiet Mark

Quiet Mark is the international approval award programme that encourages companies worldwide to prioritise noise reduction within the design of everyday machines and appliances, and find solutions to noise problems.

“AEG gives consumers the confidence to put woollen garments into a machine, which has been lacking for the last 30–40 years.”

PETER ACKROYD
The Woolmark Company





OUR TUMBLE DRYER RANGE

Our tumble dryer range is structured into 2 series levels. As you go up the series levels, our tumble dryers step up the level of fabric care, and include all the technologies from the series below.





	7000 SERIES	8000 SERIES
 AbsoluteCare® System		<input checked="" type="checkbox"/>
 SensiDry® Technology	<input checked="" type="checkbox"/>	<input checked="" type="checkbox"/>
 ProSense® Technology	<input checked="" type="checkbox"/>	<input checked="" type="checkbox"/>

TUMBLE DRYERS

Never dared to tumble dry wool, silk or outdoor garments before? Now you can tumble dry everything you wash with the AbsoluteCare® System. Have tailored programming to control precisely the movement and temperature of the drying drum. Holding delicate fibres aloft so silks keep their shape and wrinkles are reduced.

8000 SERIES



8000 Series Tumble Dryer
T8DEC846R

TECHNOLOGY

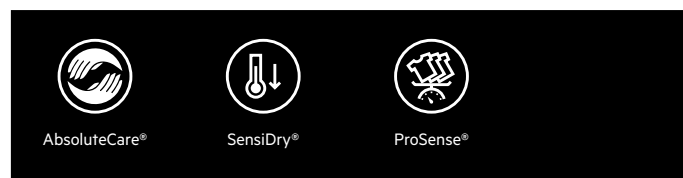

AbsoluteCare®

DualSense® Technology tailors the temperature and motion of the drum to different fabrics. Everything from textured jackets to soft jumpers can be carefully washed, dried and cared for in one go.



SensiDry®

SensiDry® Technology reduces the drying temperature by almost half (compared to a condenser washer dryer) – reducing damage and wear, and maintaining the texture of your fabrics.



ProSense®

Automatically adjusts the time, water and energy consumption to suit any load size.

Specifications

Drum: 8kg	Energy rating: A++
------------------	---------------------------

Programmes

Cottons	Synthetics
Bedlinen	Outdoor
Easy Iron	Wool
Mixed	Duvet
Silk	Sports

Additional Features

Refresh	Delay start
Anti-crease	Time drying
Dryness level	Start/Pause
Quiet mode	Child lock

Colour: Stainless steel fascia panel

Appliance Dimensions (HxWxD) in mm: 850 x 600 x 665

7000 SERIES



7000 Series Tumble Dryer
T7DEE835R

TECHNOLOGY



Specifications

Drum: 8kg	Energy rating: A+
------------------	--------------------------

Programmes

Cottons	Synthetics
Bedlinen	Wool
Easy Iron	Duvet
Mixed	Active Wear
Silk	Sports

Additional Features

Anti-crease	Start/Pause
Dryness level	Child lock
Delay start	
Time drying	

Colour: Silver fascia panel

Appliance Dimensions (HxWxD) in mm: 850 x 600 x 665

Refresh programme

Add the refresh option to your cottons and synthetics dry cycle to reduce creases and folds.

OUR WASHER DRYER RANGE

We've taken the best technologies of our washing machines and tumble dryers and incorporated them into one solution so you can wash and dry in one go.





WASHER DRYERS

With the same performance and technologies as two separate machines, you can wash and dry in one go.

We offer complete care for your woollens throughout the wash and dry cycle.

7000 SERIES



7000 Series Washer Dryer
L7WEE965R

TECHNOLOGY

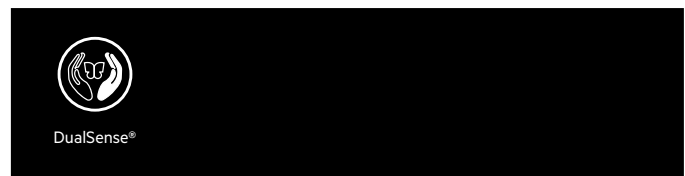

Specifications

Drum: 9/6kg	Energy rating: A
Speed: 1600rpm	

Programmes

Cottons	Outdoor
Cotton Eco	Anti-Allergy
Synthetics	NonStop 60min
Delicates	Steam
Wool/Handwash	Rinse

Additional Features

Quick wash	Start/Pause
Temperature selection	Child lock
Stains/Prewash	Spin selection
Delay start	
Wash/Dry	
Time drying	

Colour: Silver fascia panel

Appliance Dimensions (HxWxD) in mm: 850 x 600 x 660



DualSense®

DualSense® Technology tailors the temperature and motion of the drum to different fabrics. Everything from textured jackets to soft jumpers can be carefully washed, dried and cared for in one go.



7000 Series Washer Dryer
L7WBG741R



Built-In Washer Dryer
L7WC8632BI – Available from September 2018

TECHNOLOGY

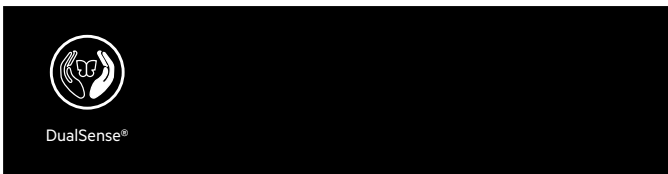

TECHNOLOGY

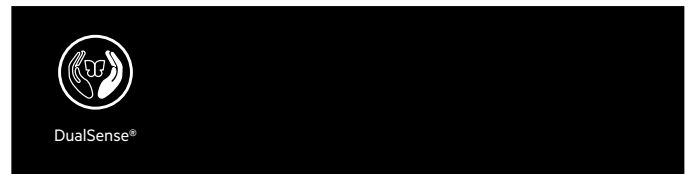

Specifications

Drum: 7/4kg	Energy rating: A
Speed: 1400rpm	

Specifications

Drum: 7/4kg	Energy rating: A
Speed: 1600rpm	

Programmes

Cottons	Outdoor
Cotton Eco	Spin/Drain
Synthetics	NonStop 60min
Delicates	Steam
Wool/Handwash	Rinse

Programmes

Cottons	NonStop 60min
Cotton Eco	Denim
Synthetics	Outdoor
Delicates	SportWear
Wool/Handwash	Anti-Allergy
Steam	Machine Clean
Spin/Drain	Rinse

Additional Features

Temperature selection	Start/Pause
Stains/Prewash	Spin selection
Delay start	Auto drying
Quick wash	Child lock
Wash/Dry	
Time drying	

Colour: White fascia panel

Appliance Dimensions (HxWxD) in mm: 850 x 600 x 576

Additional Features

Anti crease	Prewash/extra rinse
Temperature selection	Auto drying
Spin selection	Time drying
Time save	Start/Pause
Delay start	Child lock
Wash/Dry	

Colour: Silver fascia panel

Appliance Dimensions (HxWxD) in mm: 820 x 596 x 555

SPECIFICATION TABLES



SENSECOOK



HOB²HOOD



COMFORTLIFT®



MAXISENSE®



REFRIGERATION



SCE8186VTC



SCE8182VNC



SCE8182VTS



SCE8191VTS

Overview	SCE8186VTC	SCE8182VNC	SCE8182VTS	SCE8191VTS
TwinTech®	•	•	•	•
NoFrost	•	•	•	•
LowFrost	•	•	•	•
CustomFlex®	•	•	•	•
LongFresh	•	•	•	•
Soft Close Doors	•	•	•	•
Multi Airflow Cooling	•	•	•	•
DynamicAir Technology	•	•	•	•
LCD Touch Display/Electronic Controls/ Mechanical Temperature Control	Electronic Touch	Electronic Touch	Electronic Touch	Simple Touch
LED Lighting	•	•	•	•
Coolmatic	•	•	•	•
Frostmatic	•	•	•	•
Holiday Mode	•	•	•	•
High Temperature Alarm	•	•	•	•
Door Open Alarm	•	•	•	•
Door Opening	Right & Reversible	Right & Reversible	Right & Reversible	Right & Reversible
Gross Capacity (ltr/cu.ft)	265	265	273	296
Net Capacity (ltr/cu.ft)	247	247	253	283
Fridge Features				
Gross Capacity Fridge (ltr/cu.ft)	189	189	197	223
Net Capacity Fridge (ltr/cu.ft)	186	186	192	219
Defrost – Fridge	Auto	Auto	Auto	Auto
Glass Shelves	3	3	3	3
Flexi Shelf (Half Depth)	•	•	•	•
Fresh Box	•	•	•	•
Bottle Rack	•	•	•	•
Large Telescopic Pull Out Salad Drawer	•	•	•	•
Large Salad Drawer	•	•	•	•
2 Extra Deep 1/2 Width Salad Drawers	2 Half Width	2 Half Width	2 Half Width	•
Full Width Recessed Salad Drawer with 2 Glass Lids	•	•	•	•
Dairy Compartment with Lid	•	•	•	•
No. Full Width Door Shelves				
1/2 Width Sliding Door Shelf	•	•	•	•
Egg Tray	2 for 6 eggs	2 for 6 eggs	2 for 6 eggs	2 for 6 eggs
Freezer Features				
Gross Capacity Freezer (ltr/cu.ft)	76	76	76	73
Net Capacity Freezer (ltr/cu.ft)	61	61	61	64
Defrost – Freezer	Auto	Auto	Auto	Auto
No. Full Width Drawers	3 Full Width	3 Full Width	3 Full Width	3 Full Width
Telescopic Freezer Drawers	•	•	•	•
Product Dimensions				
Height (mm)	1769	1769	1772	1842
Width (mm)	556	556	540	540
Depth (mm)	549	549	549	552
Built-in Dimensions				
Built-in Height (mm)	1769	1769	1772	1842
Built-in Width (mm)	556	556	540	540
Built-In Depth (mm)	549	549	549	552
Door Fixing	BI DoD	BI DoD	BI Slide Door	BI Slide Door
Performance				
Annual Energy Consumption	120	226	228	307
Energy Efficiency Class	A+++	A++	A++	A+
Climate Class	SN-N-ST-T	SN-N-ST-T	SN-N-ST-T	SN-N-ST-T
Noise	39	39	39	39
Freezing Capacity	10	10	10	8
Power Cut Safe Rising Time	23	23	21	21
Minimum Ambient Temperature	10	10	10	10



SCE8192VTS



SCE8182XNC



SCE8182XTS



SCE8181VNS

Overview				
TwinTech®	•	•	•	•
NoFrost	•	•	•	•
LowFrost				
CustomFlex®				
LongFresh				
Soft Close Doors			•	
Multi Airflow Cooling				
DynamicAir Technology	•			
LCD Touch Display/Electronic Controls/ Mechanical Temperature Control	Simple Touch	Electronic Touch	Electronic Touch	Electronic Touch
LED Lighting	•	•	•	•
Coolmatic	•	•	•	•
Frostmatic	•	•	•	•
Holiday Mode	•	•	•	•
High Temperature Alarm	•	•	•	•
Door Open Alarm				
Door Opening	Right & Reversible	Right & Reversible	Right & Reversible	Right & Reversible
Gross Capacity (ltr/cu.ft)	296	265	264	264
Net Capacity (ltr/cu.ft)	283	247	239	239
Fridge Features				
Gross Capacity Fridge (ltr/cu.ft)	223	189	157	157
Net Capacity Fridge (ltr/cu.ft)	219	186	152	152
Defrost – Fridge	Auto	Auto	Auto	Auto
Glass Shelves	3	3	2	2
Flexi Shelf (Half Depth)	•	•	•	•
Fresh Box	•			
Bottle Rack				
Large Telescopic Pull Out Salad Drawer				
Large Salad Drawer				
2 Extra Deep 1/2 Width Salad Drawers		2 Half Width	2 Half Width	2 Half Width
Full Width Recessed Salad Drawer with 2 Glass Lids				
Dairy Compartment with Lid	•	•	•	•
No. Full Width Door Shelves				
1/2 Width Sliding Door Shelf	•	•	•	•
Egg Tray	2 for 6 eggs	2 for 6 eggs	2 for 6 eggs	2 for 6 eggs
Freezer Features				
Gross Capacity Freezer (ltr/cu.ft)	73	76	107	107
Net Capacity Freezer (ltr/cu.ft)	64	61	87	87
Defrost – Freezer	Auto	Auto	Auto	Auto
No. Full Width Drawers	3 Full Width	3 Full Width	4 Full Width	4 Full Width
Telescopic Freezer Drawers				
Product Dimensions				
Height (mm)	1842	1769	1772	1772
Width (mm)	540	556	540	540
Depth (mm)	552	549	549	549
Built-in Dimensions				
Built-in Height (mm)	1842	1769	1772	1772
Built-in Width (mm)	540	556	540	540
Built-In Depth (mm)	552	549	549	549
Door Fixing	BI Slide Door	BI DoD	BI Slide Door	BI Slide Door
Performance				
Annual Energy Consumption	241	226	238	303
Energy Efficiency Class	A++	A++	A++	A+
Climate Class	SN-N-ST-T	SN-N-ST-T	SN-N-ST-T	SN-N-ST-T
Noise	39	39	39	39
Freezing Capacity	8	10	10	10
Power Cut Safe Rising Time	21	23	25	25
Minimum Ambient Temperature	10	10	10	10

REFRIGERATION



SCE181VTS



SCB6181XLS



SCB6181VLS



SCB5142VLS

Overview	SCE181VTS	SCB6181XLS	SCB6181VLS	SCB5142VLS
TwinTech®	•			
NoFrost	•			
LowFrost		•	•	•
CustomFlex®				
LongFresh				
Soft Close Doors				
Multi Airflow Cooling				
DynamicAir Technology	•			
LCD Touch Display/Electronic Controls/ Mechanical Temperature Control	Electronic Touch	Simple Touch	Simple Touch	Mechanical Control
LED Lighting	•	•	•	•
Coolmatic	•			
Frostmatic	•	•	•	
Holiday Mode	•			
High Temperature Alarm	•			
Door Open Alarm	•			
Door Opening	Right & Reversible	Right & Reversible	Right & Reversible	Right & Reversible
Gross Capacity (ltr/cu.ft)	273	272	269	220
Net Capacity (ltr/cu.ft)	253	268	266	217
Fridge Features				
Gross Capacity Fridge (ltr/cu.ft)	197	199	163	163
Net Capacity Fridge (ltr/cu.ft)	192	196	160	160
Defrost – Fridge	Auto	Auto	Auto	Auto
Glass Shelves	3	4	3	3
Flexi Shelf (Half Depth)	•			
Fresh Box				
Bottle Rack				
Large Telescopic Pull Out Salad Drawer				
Large Salad Drawer				
2 Extra Deep 1/2 Width Salad Drawers	2 Half Width	2 Half Width	2 Half Width	2 Half Width
Full Width Recessed Salad Drawer with 2 Glass Lids				
Dairy Compartment with Lid	•	•	•	•
No. Full Width Door Shelves				
1/2 Width Sliding Door Shelf	•		•	•
Egg Tray	2 for 6 eggs	2 for 6 eggs	2 for 6 eggs	2 for 6 eggs
Freezer Features				
Gross Capacity Freezer (ltr/cu.ft)	76	73	106	57
Net Capacity Freezer (ltr/cu.ft)	61	72	106	57
Defrost – Freezer	Auto	Manual	Manual	Manual
No. Full Width Drawers	3 Full Width	3 Full Width	4 Full Width	2 Full Width
Telescopic Freezer Drawers				
Product Dimensions				
Height (mm)	1772	1772	1772	1441
Width (mm)	540	540	540	540
Depth (mm)	549	549	549	549
Built-in Dimensions				
Built-in Height (mm)	1772	1772	1772	1441
Built-in Width (mm)	540	540	540	540
Built-In Depth (mm)	549	549	549	549
Door Fixing	BI Slide Door	BI Slide Door	BI Slide Door	BI Slide Door
Performance				
Annual Energy Consumption	291	291	293	204
Energy Efficiency Class	A+	A+	A+	A++
Climate Class	SN-N-ST-T	SN-N-ST-T	SN-N-ST	SN-N-ST-T
Noise	39	36	36	35
Freezing Capacity	10	4	4	4
Power Cut Safe Rising Time	21	22	22	20
Minimum Ambient Temperature	10	10	10	10



ABE6821VNF



ABE6822VAF



ABB6821VAF



SFB5821VAF

Overview

TwinTech®				
NoFrost	•			
LowFrost				
CustomFlex®				
LongFresh				
Soft Close Doors				
Multi Airflow Cooling				
DynamicAir Technology				
LCD Touch Display/Electronic Controls/ Mechanical Temperature Control	Electronic	Electronic	Electronic	Mechanical
LED Lighting				•
Coolmatic				
Frostmatic	•	•	•	
Holiday Mode				
High Temperature Alarm	•	•	•	
Door Open Alarm	•	•	•	
Door Opening	Right & Reversible	Right & Reversible	Right & Reversible	Right & Reversible
Gross Capacity (ltr/cu.ft)	86	105	105	111
Net Capacity (ltr/cu.ft)	85	95	95	109
Fridge Features				
Gross Capacity Fridge (ltr/cu.ft)				111
Net Capacity Fridge (ltr/cu.ft)				109
Defrost – Fridge				Auto
Glass Shelves				2
Flexi Shelf (Half Depth)				
Fresh Box				
Bottle Rack				
Large Telescopic Pull Out Salad Drawer				
Large Salad Drawer				1 Full Width
2 Extra Deep 1/2 Width Salad Drawers				
Full Width Recessed Salad Drawer with 2 Glass Lids				
Dairy Compartment with Lid				•
No. Full Width Door Shelves				
1/2 Width Sliding Door Shelf				•
Egg Tray				1 for 6 eggs
Freezer Features				
Gross Capacity Freezer (ltr/cu.ft)	86	105	105	
Net Capacity Freezer (ltr/cu.ft)	85	95	95	
Defrost – Freezer	Auto	Manual	Manual	
No. Full Width Drawers	3 Full Width	3 Full Width	3 Full Width	
Telescopic Freezer Drawers	•			
Product Dimensions				
Height (mm)	815	815	815	815
Width (mm)	596	596	596	596
Depth (mm)	550	550	550	550
Built-in Dimensions				
Built-in Height (mm)	815	815	815	815
Built-in Width (mm)	596	596	596	596
Built-In Depth (mm)	550	550	550	550
Door Fixing	BI UC DoD	BI UC DoD	BI UC DoD	BI UC DoD
Performance				
Annual Energy Consumption	191	147	187	172
Energy Efficiency Class	A+	A++	A+	A+
Climate Class	SN-N-ST-T	SN-N-ST-T	SN-N-ST-T	SN-N-ST
Noise	41	38	38	38
Freezing Capacity	12	18	18	2.5
Power Cut Safe Rising Time	13	29	29	13
Minimum Ambient Temperature	10	10	10	10

REFRIGERATION



SF5E822VAF



SKB5821VAF



SKE5822VAF



ABK8182VNC

Overview	SF5E822VAF	SKB5821VAF	SKE5822VAF	ABK8182VNC
TwinTech®				
NoFrost				•
LowFrost				
CustomFlex®				
LongFresh				
Soft Close Doors				•
Multi Airflow Cooling				
DynamicAir Technology				
LCD Touch Display/Electronic Controls/ Mechanical Temperature Control	Mechanical	Mechanical	Mechanical	Electronic Touch
LED Lighting	•	•	•	
Coolmatic				
Frostmatic				•
Holiday Mode				
High Temperature Alarm				•
Door Open Alarm				•
Door Opening	Right & Reversible	Right & Reversible	Right & Reversible	Right & Reversible
Gross Capacity (ltr/cu.ft)	111	136	136	216
Net Capacity (ltr/cu.ft)	109	133	133	204
Fridge Features				
Gross Capacity Fridge (ltr/cu.ft)	111	136	136	
Net Capacity Fridge (ltr/cu.ft)	109	133	133	
Defrost – Fridge	Auto	Auto	Auto	
Glass Shelves	2	3	3	
Flexi Shelf (Half Depth)				
Fresh Box				
Bottle Rack				
Large Telescopic Pull Out Salad Drawer				
Large Salad Drawer	1 Full Width	1 Full Width	1 Full Width	
2 Extra Deep 1/2 Width Salad Drawers				
Full Width Recessed Salad Drawer with 2 Glass Lids				
Dairy Compartment with Lid	•	•	•	
No. Full Width Door Shelves				
1/2 Width Sliding Door Shelf	•	•	•	
Egg Tray	1 for 6 eggs	1 for 6 eggs	1 for 6 eggs	
Freezer Features				
Gross Capacity Freezer (ltr/cu.ft)				216
Net Capacity Freezer (ltr/cu.ft)				204
Defrost – Freezer				Auto
No. Full Width Drawers				5 Full Width
Telescopic Freezer Drawers				
Product Dimensions				
Height (mm)	815	815	815	1769
Width (mm)	596	596	596	556
Depth (mm)	550	550	550	549
Built-in Dimensions				
Built-in Height (mm)	815	815	815	1769
Built-in Width (mm)	596	596	596	556
Built-In Depth (mm)	550	550	550	549
Door Fixing	BI UC DoD	BI UC DoD	BI UC DoD	BI DoD
Performance				
Annual Energy Consumption	139	118	91	238
Energy Efficiency Class	A++	A+	A++	A++
Climate Class	SN-N-ST-T	SN-N-ST-T	SN-N-ST-T	SN-N-ST-T
Noise	36	36	36	39
Freezing Capacity	2.5			20
Power Cut Safe Rising Time	13			24
Minimum Ambient Temperature	10	10	10	10



ABE8122VNC



SKK8182VZC



SKK8182VDC



SKE8122VAC

Overview

TwinTech®				
NoFrost	•			
LowFrost				
CustomFlex®				
LongFresh		•		
Soft Close Doors	•	•		•
Multi Airflow Cooling			•	
DynamicAir Technology				
LCD Touch Display/Electronic Controls/ Mechanical Temperature Control	Electronic;Touch	Electronic Touch	Electronic Touch	
LED Lighting		•	•	•
Coolmatic		•	•	•
Frostmatic	•			
Holiday Mode			•	•
High Temperature Alarm	•			
Door Open Alarm	•	•	•	•
Door Opening	Right & Reversible	Right & Reversible	Right & Reversible	Right & Reversible
Gross Capacity (ltr/cu.ft)	130	298	314	205
Net Capacity (ltr/cu.ft)	120	275	310	202
Fridge Features				
Gross Capacity Fridge (ltr/cu.ft)		298	314	205
Net Capacity Fridge (ltr/cu.ft)		275	310	202
Defrost – Fridge		Auto	Auto	Auto
Glass Shelves		3	4	3
Flexi Shelf (Half Depth)		•	•	•
Fresh Box			•	
Bottle Rack			•	
Large Telescopic Pull Out Salad Drawer				
Large Salad Drawer				
2 Extra Deep 1/2 Width Salad Drawers				2 Half Width
Full Width Recessed Salad Drawer with 2 Glass Lids				
Dairy Compartment with Lid		•	•	•
No. Full Width Door Shelves				
1/2 Width Sliding Door Shelf		•	•	•
Egg Tray		2 for 6 eggs	2 for 6 eggs	2 for 6 eggs
Freezer Features				
Gross Capacity Freezer (ltr/cu.ft)	130			
Net Capacity Freezer (ltr/cu.ft)	120			
Defrost – Freezer	Auto			
No. Full Width Drawers	4 Full Width			
Telescopic Freezer Drawers		•	•	
Product Dimensions				
Height (mm)	1224	1769	1769	1219
Width (mm)	556	556	556	556
Depth (mm)	549	549	549	550
Built-in Dimensions				
Built-in Height (mm)	1224	1769	1769	1219
Built-in Width (mm)	556	556	556	556
Built-In Depth (mm)	549	549	549	550
Door Fixing	BI DoD	BI DoD	BI DoD	BI DoD
Performance				
Annual Energy Consumption	183	130	114	103
Energy Efficiency Class	A++	A++	A++	A++
Climate Class	SN-N-ST-T	SN-N-ST-T	SN-N-ST-T	SN-N-ST-T
Noise	39	37	35	35
Freezing Capacity	20			
Power Cut Safe Rising Time	22			
Minimum Ambient Temperature	10	10	10	10

REFRIGERATION



RMB76111NX



RMB76311NX

Overview		
TwinTech®		
NoFrost	•	•
LowFrost		
CustomFlex®		
LongFresh		
Soft Close Doors		
Multi Airflow Cooling	•	•
DynamicAir Technology		
LCD Touch Display/Electronic Controls/ Mechanical Temperature Control	LCD touch	Electronic Touch
LED Lighting	•	•
Coolmatic	•	•
Frostmatic	•	•
Holiday Mode	•	•
High Temperature Alarm	•	•
Door Open Alarm	•	
Door Opening	Side by side	Left & Right
Gross Capacity (l/cu.ft)	608	630
Net Capacity (l/cu.ft)	549	536
Fridge Features		
Gross Capacity Fridge (l/cu.ft)	380	436
Net Capacity Fridge (l/cu.ft)	370	417
Defrost – Fridge	Auto	Auto
Glass Shelves	4	2
Flexi Shelf (Half Depth)		
Fresh Box	•	
Bottle Rack		
Large Telescopic Pull Out Salad Drawer		
Large Salad Drawer	3 Full Width	
2 Extra Deep 1/2 Width Salad Drawers		2 Half Width
Full Width Recessed Salad Drawer with 2 Glass Lids		
Dairy Compartment with Lid	•	•
No. Full Width Door Shelves		
1/2 Width Sliding Door Shelf		
Egg Tray	1 for 6 eggs	1 for 14 eggs
Freezer Features		
Gross Capacity Freezer (l/cu.ft)	228	194
Net Capacity Freezer (l/cu.ft)	179	119
Defrost – Freezer	Auto	Auto
No. Full Width Drawers	2 Full width	2/slide trays + 1 slide drawer
Telescopic Freezer Drawers		•
Product Dimensions		
Height (mm)	1860	1776
Width (mm)	1190	912
Depth (mm)	623	765
Built-in Dimensions		
Built-in Height (mm)	1860	1776
Built-in Width (mm)	1190	912
Built-in Depth (mm)	623	765
Door Fixing	FS	FS
Performance		
Annual Energy Consumption	467	410
Energy Efficiency Class	A+	A+
Climate Class	SN-N-ST-T	SN-N-ST-T
Noise	43	43
Freezing Capacity	16	10
Power Cut Safe Rising Time	10	12
Minimum Ambient Temperature	10	10

REFRIGERATION



SWE66001DG



SWE63001DG



SWE61501DG

Overview

TwinTech®			
NoFrost			
LowFrost			
CustomFlex®			
LongFresh			
Soft Close Doors			
Multi Airflow Cooling			
DynamicAir Technology			
LCD Touch Display/Electronic Controls/ Mechanical Temperature Control	Electronic	Electronic	Electronic
LED Lighting	•	•	•
Coolmatic			
Frostmatic			
Holiday Mode			
High Temperature Alarm			
Door Open Alarm			
Door Opening	Right & Reversible	Right & Reversible	Right
Gross Capacity (ltr/cu.ft)			
Net Capacity (ltr/cu.ft)			
Capacity	46 Bottles	18 Bottles	7 Bottles
Fridge Features			
Gross Capacity Fridge (ltr/cu.ft)	145	58	22
Net Capacity Fridge (ltr/cu.ft)	138	56	22
Defrost – Fridge			
Glass Shelves	6	6	6
Flexi Shelf (Half Depth)			
Fresh Box			
Bottle Rack			
Large Telescopic Pull Out Salad Drawer			
Large Salad Drawer			
2 Extra Deep 1/2 Width Salad Drawers			
Full Width Recessed Salad Drawer with 2 Glass Lids			
Dairy Compartment with Lid			
No. Full Width Door Shelves			
1/2 Width Sliding Door Shelf			
Egg Tray			
Freezer Features			
Gross Capacity Freezer (ltr/cu.ft)			
Net Capacity Freezer (ltr/cu.ft)			
Defrost – Freezer			
No. Full Width Drawers			
Telescopic Freezer Drawers			
Product Dimensions			
Height (mm)	820	820	870
Width (mm)	595	294	148
Depth (mm)	565	571	526
Built-in Dimensions			
Built-in Height (mm)	820	820	870
Built-in Width (mm)	595	294	148
Built-In Depth (mm)	565	571	526
Door Fixing	BI Wide Door	BI Wide Door	BI Wide Door
Performance			
Annual Energy Consumption	149	140	137
Energy Efficiency Class	A	A	A
Climate Class	N-ST	N-ST	N-ST
Noise	39	39	35
Freezing Capacity			
Power Cut Safe Rising Time			
Minimum Ambient Temperature	16	16	16

SINGLE OVENS



BSK892330M



BSK792320M



BSE792320B



BSK882320M

Oven Features

	Command Wheel	Touch	Touch	Command Wheel
Control Type	Command Wheel	Touch	Touch	Command Wheel
Illuminated Controls				
Menu Guided Cooking	Yes	Yes	Yes	Yes
Oven Capacity (Usable)	70	70	70	70
Number of Functions	21	24	24	18
Fast Heat Up	Yes	Yes	Yes	Yes
SoftMotion™ Soft Close Door	Yes	Yes	Yes	Yes
Fully Programmable Timer	Yes	Yes	Yes	Yes
Core Temperature Sensor	Yes	Yes	Yes	Yes
FloodLight™	Yes	Yes	Yes	Yes
SideLight	Yes	Yes	Yes	Yes
Cleaning	Steam	Steam	Steam	Steam
Oven Door Glazing	Four	Four	Four	Four
Cooling Fan	Yes	Yes	Yes	Yes
Steam	Yes	Yes	Yes	Yes

Accessories

Number of Shelves	Two	Two	Two	Two
Telescopic Runners	Yes	Yes	Yes	Yes
MaxiTray™	Yes	Yes	Yes	Yes
Full Width Grill/Meat Pan (with Trivet)	Yes	Yes	Yes	Yes
Perforated Baking Trays	Yes	Yes	Yes	Yes
Patisserie Tray	Yes	Yes	Yes	

Dimensions

Appliance Dimensions				
Height (mm)	594	594	594	594
Width (mm)	595	595	595	595
Depth (mm)	567	567	567	567
Aperture Dimensions				
Height (mm)	590	590	590	590
Width (mm)	560	560	560	560
Depth (mm)	550	550	550	550

Performance

Oven Temperature Range (°C)	30°C-230°C	30°C-230°C	30°C-230°C	30°C-230°C
Energy Efficiency Class	A++	A+	A+	A+
Energy Efficiency Class in Mode Static/Fan	Fan	Fan	Fan	Fan
Energy Consumption Fan (kWh)	0.52	0.68	0.68	0.68
Energy Consumption Static (kWh)	0.99	0.89	0.89	0.99
Largest Baking Sheet Surface Area	1424	1424	1424	1424
Connected Load (W)	3200	3500	3500	3500
Fuse Rating (A)	16	16	16	16

SINGLE OVENS



BSK78232PM



BSK874320M



BSK774320M

Oven Features

	Touch	Command Wheel	Touch
Control Type	Touch	Command Wheel	Touch
Illuminated Controls			
Menu Guided Cooking	Yes	Yes	Yes
Oven Capacity (Usable)	70	71	71
Number of Functions	18	18	18
Fast Heat Up	Yes	Yes	Yes
SoftMotion™ Soft Close Door	Yes	Yes	Yes
Fully Programmable Timer	Yes	Yes	Yes
Core Temperature Sensor	Yes	Yes	Yes
FloodLight™	Yes	Yes	Yes
SideLight	Yes	Yes	Yes
Cleaning	Steam	Steam	Steam
Oven Door Glazing	Four	Four	Four
Cooling Fan	Yes	Yes	Yes
Steam	Yes	Yes	Yes

Accessories

Number of Shelves	Two	Two	Two
Telescopic Runners	Yes	Yes	Yes
MaxiTray™	Yes	Yes	Yes
Full Width Grill/Meat Pan (with Trivet)	Yes	Yes	Yes
Perforated Baking Trays			
Patisserie Tray			

Dimensions

Appliance Dimensions			
Height (mm)	594	594	594
Width (mm)	595	595	595
Depth (mm)	567	567	567
Aperture Dimensions			
Height (mm)	590	590	590
Width (mm)	560	560	560
Depth (mm)	550	550	550

Performance

Oven Temperature Range (°C)	30°C-300°C	30°C-300°C	30°C-300°C
Energy Efficiency Class	A+	A+	A+
Energy Efficiency Class in Mode Static/Fan	Fan	Fan	Fan
Energy Consumption Fan (kWh)	0.69	0.69	0.69
Energy Consumption Static (kWh)	0.99	0.99	0.99
Largest Baking Sheet Surface Area	1424	1424	1424
Connected Load (W)	3500	3500	3500
Fuse Rating (A)	16	16	16

SINGLE OVENS



BPK842720M



BPK742320M



BPK744L21M/R21M



BPK742320B

Oven Features

Control Type	Command Wheel	Touch	Touch	Touch
Illuminated Controls		No		No
Menu Guided Cooking		Yes	Yes	Yes
Oven Capacity (Usable)	71	71	71	71
Number of Functions	13	17	21	17
Fast Heat Up	Yes	Yes	Yes	Yes
SoftMotion™ Soft Close Door	Yes	Yes		Yes
Fully Programmable Timer	Yes	Yes	Yes	Yes
Core Temperature Sensor	Yes	Yes	Yes	Yes
FloodLight™	Yes	Yes	Yes	Yes
SideLight	Yes	Yes	Yes	Yes
Cleaning	Pyrolytic	Pyrolytic	Pyrolytic	Pyrolytic
Oven Door Glazing	Four	Four	Four	Four
Cooling Fan	Yes	Yes	Yes	Yes
Steam				

Accessories

Number of Shelves	Two	Two	Two	Two
Telescopic Runners		Yes		Yes
MaxiTray™	Yes	Yes	Yes	Yes
Full Width Grill/Meat Pan (with Trivet)	Yes	Yes	Yes	Yes
Perforated Baking Trays				
Patisserie Tray				

Dimensions

Appliance Dimensions				
Height (mm)	594	594	594	594
Width (mm)	595	595	594	595
Depth (mm)	567	567	568	567
Aperture Dimensions				
Height (mm)	590	590	600	590
Width (mm)	560	560	560	560
Depth (mm)	550	550	550	550

Performance

Oven Temperature Range (°C)	30°C–300°C	30°C–300°C	30°C–300°C	30°C–300°C
Energy Efficiency Class	A+	A+	A+	A+
Energy Efficiency Class in Mode Static/Fan	Fan	Fan	Fan	Fan
Energy Consumption Fan (kWh)	0.69	0.69	0.69	0.69
Energy Consumption Static (kWh)	0.99	0.99	0.93	0.99
Largest Baking Sheet Surface Area	1424	1424	1424	1424
Connected Load (W)	3500	3500	3480	3500
Fuse Rating (A)	16	16	16	16



BPK55632PM



BPK351020M



BCK45631PM

Oven Features

	Retractable + Touch	Retractable	Retractable + Touch
Control Type	Retractable + Touch	Retractable	Retractable + Touch
Illuminated Controls			
Menu Guided Cooking			
Oven Capacity (Usable)	71	71	71
Number of Functions	10	10	9
Fast Heat Up	Yes	Yes	
SoftMotion™ Soft Close Door	Yes		Yes
Fully Programmable Timer	Yes	Yes	Yes
Core Temperature Sensor	Yes	Yes	Yes
FloodLight™	Yes		Yes
SideLight	Yes	Yes	Yes
Cleaning	Pyrolytic	Pyrolytic	Catalytic
Oven Door Glazing	Three	Four	Three
Cooling Fan	Yes	Yes	Yes
Steam			
Accessories			
Number of Shelves	Two	Two	Two
Telescopic Runners	Yes		Yes
MaxiTray™	Yes	Yes	Yes
Full Width Grill/Meat Pan (with Trivet)	Yes	Yes	Yes
Perforated Baking Trays			
Patisserie Tray			
Dimensions			
Appliance Dimensions			
Height (mm)	594	594	594
Width (mm)	594	595	595
Depth (mm)	567	567	567
Aperture Dimensions			
Height (mm)	590	590	590
Width (mm)	560	560	560
Depth (mm)	550	550	550
Performance			
Oven Temperature Range (°C)	30°C-300°C	30°C-300°C	50°C-275°C
Energy Efficiency Class	A+	A+	A
Energy Efficiency Class in Mode Static/Fan	Fan	Fan	Fan
Energy Consumption Fan (kWh)	0.69	0.69	0.88
Energy Consumption Static (kWh)	0.99	0.99	0.99
Largest Baking Sheet Surface Area	1418	1418	1418
Connected Load (W)	3200	3200	3200
Fuse Rating (A)	16	16	16

DOUBLE OVENS



DCK731110M

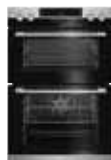

DCK431110M



DUK731110M

Oven Features

T=Top/B=Bottom			
Control Type	Touch	Retractable	Touch
Oven Capacity (Usable)	39/61	43/68	39/46
Number of Cooking Functions	8/10	6/8	8/10
Fully Programmable Timer	Yes	Yes	Yes
Cleaning	Catalytic	Catalytic	Catalytic
Oven Doors Glazing	3/3	2/2	3/3
Lights	1/1	1/1	1/1
Cooling Fan	Yes	Yes	Yes

Accessories

Number of Shelves	2/2	1/2	1/2
Full Width Grill/Meat Pan (with Trivet)	Yes/Yes	-/Yes	-/Yes

Dimensions

Appliance Dimensions			
Height (mm)	888	888	715
Width (mm)	594	594	594
Depth (mm)	548	548	548
Aperture Dimensions			
Height (mm)	875	875	870
Width (mm)	560	560	600
Depth (mm)	550	550	550

Performance

Energy Efficiency Class	A/A	A/A	A/A
Energy Efficiency Class in Mode Static/Fan	Fan/Fan	Static/Fan	Fan/Fan
Energy Consumption Fan (kWh)	0.79/0.82	N/A/0.86	0.79/0.79
Cook Time Standard Load Fan (min)	49/49	NA/44	49/48
Energy Consumption Static (kWh)	0.89/0.89	0.78/0.86	0.85/0.75
Cook Time Standard Load Static (min)	52/52	48/45	53/50
Largest Baking Sheet Surface Area (cm2)	1175	1175	1175
Connected Load (W)	5800	5100	5900
Fuse Rating (A)	30	30	30

COMBI OVENS



KMK861000M



KMK761000M



KME761000B



KMK565000M

Oven Features

Combi Microwave, Fan Oven and Grill	Yes	Yes	Yes	Yes
Duo Microwave and Grill	Yes	Yes	Yes	Yes
Solo Microwave	Yes	Yes	Yes	Yes
Oven Volume (ltr)	43	43	43	43
Auto Defrost By Weight Programmes				
Auto Cook By Weight Programmes				
Control Type	Command Wheel	Touch	Touch	Retractable + Touch
Electronic Clock/Programmer	Yes	Yes	Yes	Yes
Quickstart	Yes	Yes	Yes	Yes
Powersave Mode	Yes	Yes	Yes	Yes
Programme End Signal	Yes	Yes	Yes	Yes
Drop Down Door	Yes	Yes	Yes	Yes

Dimensions

Appliance Dimensions				
Height (mm)	455	455	455	455
Width (mm)	594	594	594	594
Depth (mm)	567	567	567	567
Built-in Dimensions				
Height (mm)	450	450	450	450
Width (mm)	560	560	560	560
Depth (mm)	550	550	550	550

Performance

Microwave Output (W)	1000	1000	1000	1000
Grill Output (W)	1900	1900	1900	1900
Convection Oven Output (W)	1650			
Connected Load (W)	3000	2000	2000	2000
Fuse Rating (A)	13	13	13	13



KMK721000M

Oven Features

Combi Microwave, Fan Oven and Grill	
Duo Microwave and Grill	Yes
Solo Microwave	Yes
Oven Volume (ltr)	43
Auto Defrost By Weight Programmes	
Auto Cook By Weight Programmes	
Control Type	Touch
Electronic Clock/Programmer	Yes
Quickstart	Yes
Powersave Mode	Yes
Programme End Signal	Yes
Drop Down Door	Yes

Dimensions

Appliance Dimensions	
Height (mm)	455
Width (mm)	594
Depth (mm)	567
Built-in Dimensions	
Height (mm)	450
Width (mm)	560
Depth (mm)	550

Performance

Microwave Output (W)	1000
Grill Output (W)	1900
Convection Oven Output (W)	
Connected Load (W)	2000
Fuse Rating (A)	13

COMPACT OVENS



KSK892220M



KSK882220M



KSK782220M



KPK842220M

Oven Features

Digital Touch Controls	Command Wheel	Command Wheel	Touch	Command Wheel
Functions	25	22	22	20
Digital Temperature Control	Yes	Yes	Yes	Yes
Fully Programmable Electronic Timer	Yes	Yes	Yes	Yes
Oven Door Glazing	Four	Four	Four	Four
Cleaning	Enamel	Enamel	Enamel	Pyrolytic
Cooling Fan	Yes	Yes	Yes	Yes
Steam	Yes	Yes	Yes	Yes
Volume (Usable)	43	43	43	43
Accessories				
Number of Shelves	One	Two	One	One
Grill/Meat Pan	Yes	Yes	Yes	Yes
Dimensions				
Appliance Dimensions				
Height (mm)	455	455	455	455
Width (mm)	594	594	594	594
Depth (mm)	567	567	567	567
Aperture Dimensions				
Height (mm)	450	450	450	450
Width (mm)	560	560	560	560
Depth (mm)	550	550	550	550
Performance				
Energy Efficiency Class	A+	A+	A+	A+
Energy Consumption Fan (kWh)	0.59	0.69	0.69	0.59
Energy Efficiency Class in Mode Static/Fan	Fan	Fan	Fan	Fan
Oven Temperature Range (°C)	30°C-230°C	30°C-230°C	30°C-300°C	30°C-300°C
Connected Load (W)	3000	3000	3000	3000
Fuse Rating (A)	13	13	13	13
Interior Lights	One Halogen	One Halogen	One Halogen	One Halogen



KPK742220M

Oven Features

Digital Touch Controls	Touch
Functions	20
Digital Temperature Control	Yes
Fully Programmable Electronic Timer	Yes
Oven Door Glazing	Four
Cleaning	Pyrolytic
Cooling Fan	Yes
Steam	
Volume (Usable)	43
Accessories	
Number of Shelves	One
Grill/Meat Pan	Yes
Dimensions	
Appliance Dimensions	
Height (mm)	455
Width (mm)	594
Depth (mm)	567
Aperture Dimensions	
Height (mm)	450
Width (mm)	560
Depth (mm)	550
Performance	
Energy Efficiency Class	A+
Energy Consumption Fan (kWh)	0.69
Energy Efficiency Class in Mode Static/Fan	Fan
Oven Temperature Range (°C)	30°C-300°C
Connected Load (W)	3000
Fuse Rating (A)	13
Interior Lights	One Halogen

COFFEE MACHINES



KKK994500M

KKK884500M/B

Features

	Command Wheel	Touch
Electronic Touch Controls		
LED Display	Yes	Yes
Automatic Cappuccino Function	Yes	Yes
Pre-Programmed Coffee Selection	Yes	Yes
Water Sensor with LED when Refill Required	Yes	Yes
Steam/Water Spout with LED Indicators	Yes	Yes
Height Adjustable Coffee Dispenser	Yes	Yes
Lamp	Yes	Yes

Dimensions

Appliance Dimensions		
Height (mm)	455	455
Width (mm)	594	594
Depth (mm)	361	361
Built-in Dimensions		
Height (mm)	450	450
Width (mm)	560	560
Depth (mm)	550	550

Electrical Connection

Connected Load (W)	1350	1350
Fuse Rating (A)	13	13
Working Pressure (Bar)	15	15

VACUUM SEALERS



KDK911423M

KDE911423B

Features

	Touch	Touch
Place settings		
Cups and glass warming (40°C)	White	White
Plate warming (60°C)	Yes	Yes
Variable temperature control	Yes	Yes
On / off LED	Yes	Yes
Anti-slip mat	Yes	Yes
Temperature range	Yes	Yes

Dimensions

Appliance Dimensions		
Height (mm)	131	131
Width (mm)	595	595
Depth (mm)	510	510
Built-in Dimensions		
Height (mm)	139	139
Width (mm)	560	560
Depth (mm)	550	550

Performance

Connected load (W)	400	400
Fuse rating (A)	13	13

WARMING DRAWERS



KDK912922M



KDE912922M



KDK911422M



KDE911422M

Features				
Place settings	12	12	6	6
Cups and glass warming (40°C)	Yes	Yes	Yes	Yes
Plate warming (60°C)	Yes	Yes	Yes	Yes
Food warming (80°C max)	Yes	Yes	Yes	Yes
Defrosting (30°C max)	Yes	Yes	Yes	Yes
Heating element	Yes	Yes	Yes	Yes
Fan air circulation	Yes	Yes	Yes	Yes
Rotary control knob	Yes	Yes	Yes	Yes
Variable temperature control	Yes	Yes	Yes	Yes
On / off LED	Yes	Yes	Yes	Yes
Anti-slip mat	Yes	Yes	Yes	Yes
Temperature range	30°C-80°C	30°C-80°C	30°C-80°C	30°C-80°C
Dimensions				
Appliance Dimensions				
Height (mm)	295	295	131	131
Width (mm)	595	595	595	595
Depth (mm)	535	535	500	500
Built-in Dimensions				
Height (mm)	295	295	139	139
Width (mm)	560	560	560	560
Depth (mm)	550	550	550	550
Performance				
Connected load (W)	550	550	430	430
Fuse rating (A)	13	13	13	13



KDE911422M



KDE911422B



KD91405M

Features			
Place settings	6	6	6
Cups and glass warming (40°C)	Yes	Yes	Yes
Plate warming (60°C)	Yes	Yes	Yes
Food warming (80°C max)	Yes	Yes	Yes
Defrosting (30°C max)	Yes	Yes	Yes
Heating element	Yes	Yes	Yes
Fan air circulation	Yes	Yes	Yes
Rotary control knob	Yes	Yes	Yes
Variable temperature control	Yes	Yes	Yes
On / off LED	Yes	Yes	Yes
Anti-slip mat	Yes	Yes	Yes
Temperature range	30-80°C	30-80°C	30-80°C
Dimensions			
Appliance Dimensions			
Height (mm)	131	131	125
Width (mm)	595	595	594
Depth (mm)	500	500	549
Built-in Dimensions			
Height (mm)	139	139	140
Width (mm)	560	560	560
Depth (mm)	550	550	539
Performance			
Connected load (W)	430	430	430
Fuse rating (A)	13	13	13

MICROWAVES



MBE2658S-M

MBB1756D-M

Features

Microwave & Grill		•
Solo Microwave	•	
Oven Volume (ltr)	26	17
Auto Defrost By Weight Programmes	4	4
Default Favourite Auto Menus	3	3
Control Type	Command wheel/ Touch on glass	Command wheel/ Touch on glass
Electronic Clock/Programmer	•	•
Quickstart	•	•
Powersave Mode	•	•
Programme End Signal	•	•

Dimensions

Appliance Dimensions		
Height (mm)	459	371
Width (mm)	596	594
Depth (mm)	404	316
Aperture Dimensions		
Height (mm)	450	360
Width (mm)	562	562
Depth (mm)	500	300

Performance

Microwave Output (W)	900	800
Grill Output (W)		800
Connected Load (W)	1400	1250
Fuse Rating (A)	10	10

INDUCTION HOBS



IAE84850FB



IKE85651FB



HKP87420FB



HK874400FB

Features				
Control Type	Touch	Touch	Touch	Touch
Display	TFT			
Control Position	Front Right	N/A	Front Right	Front Middle
Bridge Function	Yes	Yes		
Automatic Heat Up (Automax)		Yes	Yes	Yes
Stop & Go	Yes	Yes	Yes	Yes
Residual Heat Indicator	Yes	Yes	Yes	Yes
OKO Timer	Yes	Yes	Yes	Yes
Minute Minder	Yes	Yes	Yes	Yes
Count Up Timer	Yes	Yes	Yes	Yes
Pot Sensors	Yes	Yes	Yes	Yes
Boosters	Yes	Yes	Yes	Yes
Child Lock	Yes	Yes	Yes	Yes
Hob ² Hood		Yes		
Zone Specification				
Front Left Spec	Induction	Induction	Induction	Induction
Front Left Rating (W)	2300/3200	2500/3200	2300/3200	2300/3200
Front Left Diameter (mm)	220	210	210	210
Rear Left Spec	Induction	Induction	Induction	Induction
Rear Left Rating (W)	2300/3200	2300/3200	2300/3200	2300/3200
Rear Left Diameter (mm)	220	210	210	210
Front Middle Spec		Induction		
Front Middle Rating (W)		2300/3200		
Front Middle Diameter (mm)		240		
Rear Middle Spec	Induction			
Rear Middle Rating (W)	2300/3200			Induction
Rear Middle Diameter (mm)	210			2300/3200
Front Right Spec	Induction	Induction	Induction	210
Front Right Rating (W)	1800/2800	2500/3200	1800/2800	2300/3200
Front Right Diameter (mm)	180	210	180	210
Rear Right Spec		Induction	Induction	
Rear Right Rating (W)		2300/3200	2300/3200	
Rear Right Diameter (mm)		210	210	
Dimensions				
Appliance Dimensions				
Width (mm)	780	810	780	780
Depth (mm)	520	520	520	520
Aperture Dimensions				
Height (mm)	44	44	50	50
Width (mm)	750	780	750	750
Depth (mm)	490	490	490	490
Electrical Connection				
Connected Load (W)	7350	7350	7400	7400
Fuse Rating (A)	30	30	30	30



IKE84471FB



IKE85431FB



IKB84431FB



IKB84401FB

Features

Control Type	Touch	Touch	Touch	Touch
Display				
Control Position	Front Right	Front Middle	Front Middle	Front Right
Bridge Function	Yes			
Automatic Heat Up (Automax)	Yes	Yes	Yes	Yes
Stop & Go	Yes	Yes	Yes	Yes
Residual Heat Indicator	Yes	Yes	Yes	Yes
OKO Timer	Yes	Yes	Yes	Yes
Minute Minder	Yes	Yes	Yes	Yes
Count Up Timer	Yes	Yes	Yes	Yes
Pot Sensors	Yes	Yes	Yes	Yes
Boosters	Yes	Yes	Yes	Yes
Child Lock	Yes	Yes	Yes	Yes
Hob ² Hood	Yes	Yes	Yes	Yes

Zone Specification

Front Left Spec	Induction	Induction	Induction	Induction
Front Left Rating (W)	2300/3200	1400/2500	2300/3200	2300/3200
Front Left Diameter (mm)	220	145	210	210
Rear Left Spec	Induction	Induction	Induction	Induction
Rear Left Rating (W)	2300/3200	2300/3200	2300/3200	2300/3200
Rear Left Diameter (mm)	220	210	210	210
Front Middle Spec		Induction		Induction
Front Middle Rating (W)		2300/3200		2300/3200
Front Middle Diameter (mm)		210		210
Rear Middle Spec	Induction			
Rear Middle Rating (W)	2300/3200			
Rear Middle Diameter (mm)	210			
Front Right Spec	Induction	Induction	Induction	
Front Right Rating (W)	1800/2800	1400/2500	2300/3200	
Front Right Diameter (mm)	180	145	210	
Rear Right Spec		Induction	Induction	Induction
Rear Right Rating (W)		2300/3200	2300/3200	2300/3200
Rear Right Diameter (mm)		210	210	210

Dimensions

Appliance Dimensions				
Width (mm)	780	780	780	780
Depth (mm)	520	520	520	520
Aperture Dimensions				
Height (mm)	44	44	44	44
Width (mm)	750	750	750	750
Depth (mm)	490	490	490	490

Electrical Connection

Connected Load (W)	7350	7350	7350	7350
Fuse Rating (A)	30	30	30	30

INDUCTION HOBS



IKE74451FB



IKE74451XB



IAE64850FB



IKE64651FB

Features				
Control Type	Touch	Touch	Touch	Touch
Display			TFT	
Control Position	Left & Right	Left & Right	Front Right	N/A
Bridge Function	Yes	Yes	Yes	Yes
Automatic Heat Up (Automax)	Yes	Yes		Yes
Stop & Go	Yes	Yes	Yes	Yes
Residual Heat Indicator	Yes	Yes	Yes	Yes
OKO Timer	Yes	Yes	Yes	Yes
Minute Minder	Yes	Yes	Yes	Yes
Count Up Timer	Yes	Yes	Yes	Yes
Pot Sensors	Yes	Yes	Yes	Yes
Boosters	Yes	Yes	Yes	Yes
Child Lock	Yes	Yes	Yes	Yes
Hob ² Hood	Yes	Yes		Yes
Zone Specification				
Front Left Spec	Induction	Induction	Induction	Induction
Front Left Rating (W)	2300/3200	2500/3200	2300/3200	2300/3200
Front Left Diameter (mm)	210	210	220	210
Rear Left Spec	Induction	Induction	Induction	Induction
Rear Left Rating (W)	2300/3200	2300/3200	2300/3200	2300/3200
Rear Left Diameter (mm)	210	210	220	210
Front Middle Spec				Induction
Front Middle Rating (W)				2300/3200
Front Middle Diameter (mm)				240
Rear Middle Spec				
Rear Middle Rating (W)				
Rear Middle Diameter (mm)				
Front Right Spec	Induction	Induction	Induction	Induction
Front Right Rating (W)	2300/3200	2500/3200	1800/2800	2300/3200
Front Right Diameter (mm)	210	210	145	210
Rear Right Spec	Induction	Induction	Induction	Induction
Rear Right Rating (W)	2300/3200	2300/3200	2300/3200	2300/3200
Rear Right Diameter (mm)	210	210	180	210
Dimensions				
Appliance Dimensions				
Width (mm)	710	710	780	810
Depth (mm)	520	520	520	520
Aperture Dimensions				
Height (mm)	44	44	44	44
Width (mm)	680	680	750	780
Depth (mm)	490	490	490	490
Electrical Connection				
Connected Load (W)	7350	7350	7350	7350
Fuse Rating (A)	30	30	30	30



HKP67420FB



HK674400FB



IKE64450FB



IKB64431FB

Features

Control Type	Touch	Touch	Touch	Touch
Display				
Control Position	Front Right	Front Middle	Front Middle	Front Right
Bridge Function	Yes	Yes	Yes	Yes
Automatic Heat Up (Automax)	Yes	Yes	Yes	Yes
Stop & Go	Yes	Yes	Yes	Yes
Residual Heat Indicator	Yes	Yes	Yes	Yes
OKO Timer	Yes	Yes	Yes	Yes
Minute Minder	Yes	Yes	Yes	Yes
Count Up Timer	Yes	Yes	Yes	Yes
Pot Sensors	Yes	Yes	Yes	Yes
Boosters	Yes	Yes	Yes	Yes
Child Lock	Yes	Yes	Yes	Yes
Hob ² Hood				Yes

Zone Specification

Front Left Spec	Induction	Induction	Induction	Induction
Front Left Rating (W)	2300/3200	2300/3200	2300/3200	2300/3700
Front Left Diameter (mm)	220	210	210	210
Rear Left Spec	Induction	Induction	Induction	Induction
Rear Left Rating (W)	2300/3200	2300/3200	2300/3200	1800/2800
Rear Left Diameter (mm)	220	210	210	180
Front Middle Spec				
Front Middle Rating (W)				
Front Middle Diameter (mm)				
Rear Middle Spec				
Rear Middle Rating (W)				
Rear Middle Diameter (mm)				
Front Right Spec	Induction	Induction	Induction	Induction
Front Right Rating (W)	1400/2500	2300/3200	2300/3200	1400/2500
Front Right Diameter (mm)	145	210	210	145
Rear Right Spec	Induction	Induction	Induction	Induction
Rear Right Rating (W)	1800/2800	2300/3200	2300/3200	1800/2800
Rear Right Diameter (mm)	180	210	210	180

Dimensions

Appliance Dimensions				
Width (mm)	620	590	590	590
Depth (mm)	520	520	520	520
Aperture Dimensions				
Height (mm)	55	55	44	44
Width (mm)	560	560	560	560
Depth (mm)	490	490	490	490

Electrical Connection

Connected Load (W)	7400	7400	7350	7350
Fuse Rating (A)	30	30	30	30

INDUCTION HOBS



IKB64401FB



HK604200IB



IKE95471FB



IKK93431FB

Features				
Control Type	Touch	Touch	Touch	Touch
Display				
Control Position	Front Right	Front Right	Front Middle	Front Middle
Bridge Function			Yes	
Automatic Heat Up (Automax)	Yes		Yes	Yes
Stop & Go	Yes		Yes	Yes
Residual Heat Indicator	Yes	Yes	Yes	Yes
OKO Timer	Yes		Yes	Yes
Minute Minder	Yes		Yes	Yes
Count Up Timer	Yes		Yes	Yes
Pot Sensors			Yes	Yes
Boosters	Yes	Yes	Yes	Yes
Child Lock	Yes	Yes	Yes	Yes
Hob ² Hood	Yes		Yes	
Zone Specification				
Front Left Spec	Induction	Induction	Induction	
Front Left Rating (W)	2300/3700	2500/2800	2300/3200	
Front Left Diameter (mm)	210	210	220	
Rear Left Spec	Induction	Induction	Induction	Induction
Rear Left Rating (W)	1800/2800	1200	2300/3200	2300/3200
Rear Left Diameter (mm)	180	145	220	210
Front Middle Spec			Induction	
Front Middle Rating (W)			1800-3700	
Front Middle Diameter (mm)			280	
Rear Middle Spec				Induction
Rear Middle Rating (W)				2300/3200
Rear Middle Diameter (mm)				210
Front Right Spec	Induction	Induction	Induction	
Front Right Rating (W)	1400/2500	1200/1800	1400/2500	
Front Right Diameter (mm)	145	145	145	
Rear Right Spec	Induction	Induction	Induction	Induction
Rear Right Rating (W)	1800/2800	1800	2300/3200	2300/3200
Rear Right Diameter (mm)	180	180	210	210
Dimensions				
Appliance Dimensions				
Width (mm)	590	590	910	910
Depth (mm)	520	520	520	410
Aperture Dimensions				
Height (mm)	44	60	44	44
Width (mm)	560	560	880	880
Depth (mm)	490	490	490	380
Electrical Connection				
Connected Load (W)	7350	3000	7200	6900
Fuse Rating (A)	30	13	30	30

COMBO HOBS



IDK84451IB



IDE84241IB

Hob Features

	Sliding DirekTouch	Touch Control
Control Type	Sliding DirekTouch	Touch Control
Display	LED	LED
Bridge Function	• (2)	• (1)
Automatic Heat Up	•	
Stop & Go	•	
Residual Heat Indicator	•	•
Timer	•	•
Pot Sensors	•	•
Child Lock	•	•

Zone Specification

Front Left Spec		
Front Left Rating (W)	2100/3700	2100/3700
Front Left Diameter (mm)	184x220	184x220
Rear Left Spec		
Rear Left Rating (W)	2100/3700	2100/3700
Rear Left Diameter (mm)	184x220	184x220
Front Right Spec		
Front Right Rating (W)	2100/3700	2100/3700
Front Right Diameter (mm)	184x220	184x220
Rear Right Spec		
Rear Right Rating (W)	2100/3700	2100/3700
Rear Right Diameter (mm)	184x220	184x220
Appliance Dimensions		
Appliance Dimensions		
Width (mm)	830	830
Depth (mm)	510	510
Aperture Dimensions		
Height (mm)	210	210
Width (mm)	805	805
Depth (mm)	490	490

Electrical Connection

Connected Load (W)	7400	7400
Fuse Rating (A)	16	16

Cooker Hood Features

	Touch on glass slider	Touch Control
Control Type	Touch on glass slider	Touch Control
Fan Speed	9 + intensive	9 + intensive
Charcoal Filter Included	•	•
Grease Filter	Aluminium mesh	Aluminium mesh
Energy Class	A+	A+
Efficiency Max (M3/H)	400	400
Efficiency Intensive (M3/H)	420	420
Noise Max Setting dB(A)	71	71

Ducted Version		
Model Denomination	IDK84452IB	IDE842412B
Charcoal Filter Included		
Efficiency Max (M3/H)	600	600
Efficiency Intensive (M3/H)	647	647
Noise Max Setting Db(A)	68	68

CERAMIC HOBS



HK634060XB

Features

Control Type	Touch
Control Position	Front Right
Automatic Heat Up (Automax)	Yes
Stop & Go	Yes
Residual Heat Indicator	Yes
Minute Minder	Yes
Count Up Timer	Yes
Child Lock	Yes

Zone Specification

Front Left Spec	Dual Hilight
Front Left Rating (W)	750/2200
Front Left Diameter (mm)	120/210
Rear Left Spec	Hilight
Rear Left Rating (W)	1200
Rear Left Diameter (mm)	145
Front Middle Spec	
Front Middle Rating (W)	
Front Middle Diameter (mm)	
Rear Middle Spec	
Rear Middle Rating (W)	
Rear Middle Diameter (mm)	
Front Right Spec	Hilight
Front Right Rating (W)	1200
Front Right Diameter (mm)	145
Rear Right Spec	Dual Hilight
Rear Right Rating (W)	1500/2400
Rear Right Diameter (mm)	170/265

Dimensions

Appliance Dimensions	
Width (mm)	576
Depth (mm)	516
Aperture Dimensions	
Height (mm)	38
Width (mm)	560
Depth (mm)	490

Electrical Connection

Connected Load (W)	7000
Fuse Rating (A)	30

GAS HOBS



HVB95450IB



HKB95540NB



HG956440SM



HVB75450IB

Features

Control Type	Touch	Rotary	Rotary	Touch
Ignition Type	Integral	Integral	Integral	Integral
Stop & Go	Yes			Yes
Minute Minder	Yes	Yes		Yes
Control Position	Front Middle	Front Middle	Front Middle	Front Middle
LED Display	Red	Red		Red
Pan Supports	Cast Iron	Cast Iron	Cast Iron	Cast Iron
Residual Heat Indicator	Yes	Yes		Yes
Hob ² Hood	Yes	Yes		Yes
Safety Thermocouples	Yes	Yes	Yes	Yes

Zone Specification

Front Left Spec	Semi Rapid Burner	Auxiliary Burner	Rapid Burner	Semi Rapid Burner
Front Left Rating (wh)	1900	1000	3000	1900
Front Left Diameter (mm)	80	54	100	80
Rear Left Spec	Semi Rapid Burner	Semi Rapid Burner	Auxiliary Burner	Semi Rapid Burner
Rear Left Rating (wh)	1900	1900	1000	1900
Rear Left Diameter (mm)	80	70	54	80
Front Middle Spec	Wok Burner		Semi Rapid Burner	Wok Burner
Front Middle Rating (wh)	3800		2000	3800
Front Middle Diameter (mm)	122		70	122
Rear Middle Spec		Wok Burner	Semi Rapid Burner	
Rear Middle Rating (wh)		3800	2000	
Rear Middle Diameter (mm)		122	70	
Front Right Spec	Auxiliary Burner	Semi Rapid Burner	Wok Burner	Auxiliary Burner
Front Right Rating (wh)	1000	1900	4000	1000
Front Right Diameter (mm)	65	70	122	65
Rear Right Spec	Semi Rapid Burner	Semi Rapid Burner	Auxiliary Burner	Semi Rapid Burner
Rear Right Rating (wh)	1900	1900	1000	1900
Rear Right Diameter (mm)	80	70	54	80
Max Gas Power (W)	10500	10500	13000	10500

Dimensions

Appliance Dimensions				
Width (mm)	880	880	894	750
Depth (mm)	510	510	510	510
Aperture Dimensions				
Height (mm)	40	40	80	52
Width (mm)	830	830	830	720
Depth (mm)	480	480	480	490

Electrical Connection

Fuse Rating (A)	13	13	13	13
-----------------	----	----	----	----

GAS HOBS



HG795840NB

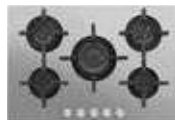

HG755820UM



HKB75540NB



HG755421UM

Features				
Control Type	Rotary	Rotary	Rotary	Rotary
Ignition Type	Integral	Integral	Integral	Integral
Stop & Go				
Minute Minder			Yes	
Control Position	Front Middle	Front Middle	Front Middle	Front Middle
LED Display			Red	
Pan Supports	Cast Iron	Cast Iron	Cast Iron	Cast Iron
Residual Heat Indicator			Yes	
Hob ² Hood			Yes	
Safety Thermocouples	Yes	Yes	Yes	Yes
Zone Specification				
Front Left Spec	Auxiliary Burner	Auxiliary Burner	Semi Rapid Burner	Semi Rapid Burner
Front Left Rating (wh)	1000	1000	1900	2000
Front Left Diameter (mm)	85.5	85.5	70	70
Rear Left Spec	Semi Rapid Burner	Semi Rapid Burner	Semi Rapid Burner	Semi Rapid Burner
Rear Left Rating (wh)	2000	2000	1900	2000
Rear Left Diameter (mm)	107.5	107.5	70	70
Front Middle Spec				
Front Middle Rating (wh)				
Front Middle Diameter (mm)				
Rear Middle Spec	Rapid Burner	Rapid Burner	Wok Burner	Wok Burner
Rear Middle Rating (wh)	2900	2900	3800	4000
Rear Middle Diameter (mm)	128.5	128.5	122	122
Front Right Spec	Auxiliary Burner	Auxiliary Burner	Auxiliary Burner	Auxiliary Burner
Front Right Rating (wh)	1000	1000	1000	1000
Front Right Diameter (mm)	85.5	85.5	54	54
Rear Right Spec	Semi Rapid Burner	Semi Rapid Burner	Semi Rapid Burner	Semi Rapid Burner
Rear Right Rating (wh)	2000	2000	1900	2000
Rear Right Diameter (mm)	107.5	107.5	70	70
Max Gas Power (W)	8900	8900	10500	11000
Dimensions				
Appliance Dimensions				
Width (mm)	740	745	740	745
Depth (mm)	510	515	510	515
Aperture Dimensions				
Height (mm)	45	45	45	45
Width (mm)	560	560	560	560
Depth (mm)	490	490	480	480
Electrical Connection				
Fuse Rating (A)	13	13	13	13



HG755450SY



HG694840NB



HG654820UM



HKB64540NB

Features

Control Type	Rotary	Rotary	Rotary	Rotary
Ignition Type	Integral	Integral	Integral	Integral
Stop & Go				
Minute Minder				Yes
Control Position	Front Middle	Front Middle	Front Middle	Front Middle
LED Display				Red
Pan Supports	Cast Iron	Cast Iron	Cast Iron	Cast Iron
Residual Heat Indicator				Yes
Hob ² Hood				Yes
Safety Thermocouples	Yes	Yes	Yes	Yes

Zone Specification

Front Left Spec	Semi Rapid Burner	Auxiliary Burner	Auxiliary Burner	Auxiliary Burner
Front Left Rating (wh)	2000	1000	1000	1000
Front Left Diameter (mm)	70	85.5	85.5	54
Rear Left Spec	Semi Rapid Burner	Rapid Burner	Rapid Burner	Rapid Burner
Rear Left Rating (wh)	2000	2900	2900	2900
Rear Left Diameter (mm)	70	128.5	128.5	100
Front Middle Spec				
Front Middle Rating (wh)				
Front Middle Diameter (mm)				
Rear Middle Spec	Wok Burner			
Rear Middle Rating (wh)	4000			
Rear Middle Diameter (mm)	122			
Front Right Spec	Auxiliary Burner	Semi Rapid Burner	Semi Rapid Burner	Semi Rapid Burner
Front Right Rating (wh)	1000	2000	2000	1900
Front Right Diameter (mm)	54	107.5	107.5	70
Rear Right Spec	Rapid Burner	Semi Rapid Burner	Semi Rapid Burner	Semi Rapid Burner
Rear Right Rating (wh)	3000	2000	2000	1900
Rear Right Diameter (mm)	100	107.5	107.5	70
Max Gas Power (W)	12000	7900	7900	7700

Dimensions

Appliance Dimensions				
Width (mm)	744	590	590	590
Depth (mm)	510	520	520	520
Aperture Dimensions				
Height (mm)	40	45	45	30
Width (mm)	560	560	560	560
Depth (mm)	480	490	490	480

Electrical Connection

Fuse Rating (A)	13	13	13	13
-----------------	----	----	----	----

GAS HOBS



HG795550XB



HG795450XB

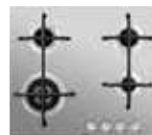

HG654421UM

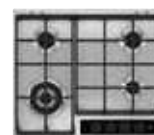

HG654550SY

Features				
Control Type	Rotary	Rotary	Rotary	Rotary
Ignition Type	Integral	Integral	Integral	Integral
Stop & Go				
Minute Minder				
Control Position	Front Middle	Front Middle	Front Right	Front Right
LED Display		0		
Pan Supports	Cast Iron	Cast Iron	Cast Iron	Cast Iron
Residual Heat Indicator				
Hob ² Hood				
Safety Thermocouples	Yes	Yes	Yes	Yes
Zone Specification				
Front Left Spec		Semi Rapid Burner	Wok Burner	Wok Burner
Front Left Rating (wh)		1900	4000	4000
Front Left Diameter (mm)		70	122	122
Rear Left Spec	Wok Burner	Semi Rapid Burner	Semi Rapid Burner	Semi Rapid Burner
Rear Left Rating (wh)	3800	1900	2000	2000
Rear Left Diameter (mm)	122	70	70	70
Front Middle Spec	Auxiliary Burner			
Front Middle Rating (wh)	1000			
Front Middle Diameter (mm)	54			
Rear Middle Spec	Semi Rapid Burner	Wok Burner		
Rear Middle Rating (wh)	1900	3800		
Rear Middle Diameter (mm)	70	122		
Front Right Spec	Semi Rapid Burner	Auxiliary Burner	Auxiliary Burner	Auxiliary Burner
Front Right Rating (wh)	1900	1000	1000	1000
Front Right Diameter (mm)	70	54	54	54
Rear Right Spec	Semi Rapid Burner	Semi Rapid Burner	Semi Rapid Burner	Semi Rapid Burner
Rear Right Rating (wh)	1900	1900	2000	2000
Rear Right Diameter (mm)	70	70	70	70
Max Gas Power (W)	10500	10500	9000	9000
Dimensions				
Appliance Dimensions				
Width (mm)	766	696	595	595
Depth (mm)	516	516	525	510
Aperture Dimensions				
Height (mm)	53	53	45	40
Width (mm)	750	680	560	560
Depth (mm)	490	490	480	480
Electrical Connection				
Fuse Rating (A)	13	13	13	13

MIXED FUEL



HD955100NB



HD634170NB

Features

	Touch/Rotary	Touch/Rotary
Control Type	Touch/Rotary	Touch/Rotary
Control Position	Front	Front
Automatic Heat Up (Automax)	Yes	Yes
Stop & Go	Yes	Yes
Residual Heat Indicator	Yes	Yes
OKO Timer	Yes	
Minute Minder	Yes	Yes
Count Up Timer	Yes	Yes
Pot Sensors	Yes	Yes
Boosters	Yes	Yes
Child Lock	Yes	Yes

Zone Specification

Front Left Spec		Induction
Front Left Rating (W)		2300/2900
Front Left Diameter (mm)		210
Rear Left Spec	Dual Crown Burner	Induction
Rear Left Rating (W)	5000	1400/2500
Rear Left Diameter (mm)	134	140
Front Middle Spec	Induction	
Front Middle Rating (W)	2200/3600	
Front Middle Diameter (mm)	210	
Rear Middle Spec	Induction	
Rear Middle Rating (W)	1400/2500	
Rear Middle Diameter (mm)	145	
Front Right Spec	Induction	Semi Rapid
Front Right Rating (W)	1400/2500	1900
Front Right Diameter (mm)	145	70
Rear Right Spec	Induction	Rapid Burner
Rear Right Rating (W)	1800/2800	2900
Rear Right Diameter (mm)	180	100

Dimensions

Appliance Dimensions		
Width (mm)	880	590
Depth (mm)	520	520
Aperture Dimensions		
Height (mm)	40	40
Width (mm)	830	560
Depth (mm)	490	490

Electrical Connection

Connected Load (W)	6800	3700
Fuse Rating (A)	30	16

CRYSTALLINE



HC452401EB



HC452601EB



HC451501EB



HC411521GB

Features				
Hob Type	2 Zone MaxiSense	Teppanyaki	Induction Wok	Wok Burner
Control Type	DirekTouch	DirekTouch	DirekTouch	Rotary
Fuel Type	Induction	Induction	Induction	Gas
Triple Zone				
Bridge Function	Yes			
Automatic Heat Up (Automax)	Yes	Yes	Yes	
Stop & Go	Yes		Yes	
Residual Heat Indicator	Yes	Yes	Yes	
Minute Minder	Yes	Yes	Yes	
Count Up Timer	Yes	Yes	Yes	
Pot Sensors	Yes		Yes	
Booster	Yes	Yes	Yes	
Child Lock	Yes	Yes	Yes	
Gas Safety Shut off				Yes
Zone Specification				
Front Spec	Induction	Induction	Induction	Double Crown
Front Rating (kW)	2.3/3.2	1.4	2.3/3.2	5
Front Diameter (mm)	170 x 265	145	300	130
Rear Spec	Induction	Induction		
Rear Rating (kW)	2.3/3.2	1.4		
Rear Diameter (mm)	170 x 265	145		
Dimensions				
Appliance Dimensions				
Width (mm)	360	360	360	360
Depth (mm)	520	520	520	520
Aperture Dimensions				
Height (mm)	55	55	55	60
Width (mm)	340	340	340	340
Depth (mm)	490	490	490	490
Electrical Connection				
Connected Load (W)	3700	3200	3200	25
Fuse Rating (A)	16	13	16	13
Lpg Conversion Kit				Yes



HC412001GB



HC452021EB

Features

Hob Type	2 Burner Gas	2 Zone Ceramic
Control Type	Rotary	DirekTouch
Fuel Type	Gas	Ceramic
Triple Zone		Yes
Bridge Function		
Automatic Heat Up (Automax)		Yes
Stop & Go		Yes
Residual Heat Indicator		Yes
Minute Minder		Yes
Count Up Timer		Yes
Pot Sensors		
Booster		
Child Lock		Yes
Gas Safety Shut off	Yes	

Zone Specification

Front Spec	Auxiliary	Single
Front Rating (kW)	1	1.2
Front Diameter (mm)	54	145
Rear Spec	Rapid	Triple
Rear Rating (kW)	2.4	0.8/1.6/2.3
Rear Diameter (mm)	100	120/175/210

Dimensions

Appliance Dimensions		
Width (mm)	360	360
Depth (mm)	520	520
Aperture Dimensions		
Height (mm)	60	38
Width (mm)	340	340
Depth (mm)	490	490

Electrical Connection

Connected Load (W)	25	3500
Fuse Rating (A)	13	16
Lpg Conversion Kit	Yes	

HOODS



DIK7190HG



DDE5980G



DCK6290HG



DVK6980HB

Overview				
Control Type	Touch on glass	Touch on glass	Electronic push buttons	Touch on glass
Hob ² Hood	•	•	•	•
Fan Speed	3+2 boost	3+2 boost	3+boost	3+2 boost
Breeze Function	•	•	•	•
Lights	Dimmable LED stripe	LED stripe	Dimmable LED stripe	Dimmable LED
No. of Lamp x W	4 x 1.75 W	1 x 7 W	2 x 12 W	2 x 1.1 W
Charcoal Filter	1;Included	2;Included	2; Accessory	2;Included
Charcoal Filter Type	TYPE15	EFB1061	EFF62	EFF62
Ultra Charcoal Filter	1; Accessory			1; Accessory
Ultra Charcoal Filter Type	SUPCHARC-E			SUPCHARCF1
Grease Filter Type	Stainless steel design filter	Aluminium cassette	Aluminium cassette	Stainless steel design filter
Ducted Maximum (ca. m3/h)	400	350	650	370
Ducted Boost (ca. m3/h)	801	700	870	720
Noise (Max. Setting) Ducted (dB(A))	54	54	67	54
Recirculation Maximum (ca. m3/h)	300	335	380	290
Recirculation Boost (ca. m3/h)	500	680	430	440
Noise (Max. Setting) Recirculation (dB(A))	75	61	74	70
Annual Energy Consumption, KWh/annum	35.1	59.5	46.4	44.9
Energy Efficiency Class	A++	A	A+	A+
Fluid Dynamic Efficiency Class	A	A	A	A
Lighting Efficiency Class	B	A	D	A
Grease Filter Efficiency	76	65.1	45	55.1
Grease Filter Efficiency Class	C	D	G	E
Off Mode Power (W)	0	0.85	0.85	0.85
Stand-by Power (W)	0.9	0		0
Installation Height (mm)				
Minimum Distance from Cooking Top ELECTRIC	50	0	65	50
Minimum Distance from Cooking Top GAS	65	5	65	50
Dimensions (mm)				
Width	1000	880	1199	898
Depth	700	95	499	396
Height Max	967	407	311	145
Height of Body	75	407	311	465
Other				
Air Outlet	150	150	150	150



DVK6680HB



DVB4850B/M



DBK7990HG



DBE6980HM

Overview

Control Type	Touch on glass	Mechanical push buttons	Touch on glass	Touch on glass
Hob ² Hood	•	•	•	•
Fan Speed	3+2 boost	3	3+2 boost	3+2 boost
Breeze Function	•	•	•	•
Lights	Dimmable LED	LED spotlight	Dimmable LED stripe	Dimmable squared LED
No. of Lamp x W	2 x 11 W	2	2 x 3.5 W	2 x 2 W
Charcoal Filter	2;Included	2;Included	1;Included	1;Included
Charcoal Filter Type	EFF62	TYPE57	TYPE15	EFF72
Ultra Charcoal Filter	1; Accessory		1; Accessory	1; Accessory
Ultra Charcoal Filter Type	SUPCHARCF1		SUPCHARC-E	SUPCHARC-F
Grease Filter Type	Stainless steel design filter	Aluminium cassette	Aluminium cassette	Stainless steel design filter
Ducted Maximum (ca. m ³ /h)	370	647	400	340
Ducted Boost (ca. m ³ /h)	720	-	801	710
Noise (Max. Setting) Ducted (dB(A))	54	67	54	54
Recirculation Maximum (ca. m ³ /h)	290	432	300	320
Recirculation Boost (ca. m ³ /h)	440		500	520
Noise (Max. Setting) Recirculation (dB(A))	70	74	75	67
Annual Energy Consumption, kWh/annum	44,9	54,6	35,1	44,6
Energy Efficiency Class	A+	B	A++	A+
Fluid Dynamic Efficiency Class	A	A	A	A
Lighting Efficiency Class	A	D	B	A
Grease Filter Efficiency	55,1	66	76	85,1
Grease Filter Efficiency Class	E	D	C	B
Off Mode Power (W)	0,85	0	0	0,85
Stand-by Power (W)		0	0,49	
Installation Height (mm)				
Minimum Distance from Cooking Top ELECTRIC	50	45	50	50
Minimum Distance from Cooking Top GAS	50	45	65	65
Dimensions (mm)				
Width	598	800	898	898
Depth	396	335	550	470
Height Max	1445		1165	920
Height of Body	465	477	75	60
Other				
Air Outlet	150	150	150	150

HOODS



DBE6780HM



DBE6680HM



DKB4950M



DKB4650M

Overview				
Control Type	Touch on glass	Touch on glass	Mechanical push buttons	Mechanical push buttons
Hob ² Hood	•	•		
Fan Speed	3+2 boost	3+2 boost	3	3
Breeze Function	•	•		
Lights	Dimmable squared LED	Dimmable squared LED	LED spotlight	LED spotlight
No. of Lamp x W	2 x 2 W	2 x 2 W	2	2
Charcoal Filter	1;Included	1;Included	1;Included	1;Included
Charcoal Filter Type	EFF72	EFF72	TYPE15	TYPE15
Ultra Charcoal Filter	1; Accessory	1; Accessory	1; Accessory	1; Accessory
Ultra Charcoal Filter Type	SUPCHARC-F	SUPCHARC-F	SUPCHARC-E	SUPCHARC-E
Grease Filter Type	Stainless steel design filter	Stainless steel design filter	Aluminium cassette	Aluminium cassette
Ducted Maximum (ca. m3/h)	340	340	603	603
Ducted Boost (ca. m3/h)	710	710	-	-
Noise (Max. Setting) Ducted (dB(A))	54	54	69	69
Recirculation Maximum (ca. m3/h)	320	320	400	400
Recirculation Boost (ca. m3/h)	520	520	-	-
Noise (Max. Setting) Recirculation (dB(A))	67	67	75	75
Annual Energy Consumption, KWh/annum	44,6	44,6	819	819
Energy Efficiency Class	A+	A+	B	B
Fluid Dynamic Efficiency Class	A	A	B	B
Lighting Efficiency Class	A	A	F	F
Grease Filter Efficiency	85,1	85,1	76	76
Grease Filter Efficiency Class	B	B	C	C
Off Mode Power (W)	0,85	0,85		
Stand-by Power (W)				
Installation Height (mm)				
Minimum Distance from Cooking Top ELECTRIC	50	50	50	50
Minimum Distance from Cooking Top GAS	65	65	65	65
Dimensions (mm)				
Width	720	598	898	598
Depth	470	470	500	500
Height Max	920	920	1090	1090
Height of Body	60	60	40	40
Other				
Air Outlet	150	150	150	150



DPB3631S



DGB3850M



DEB2631S

Overview

	Mechanical push buttons	Electronic push buttons	Electronic slider
Control Type	Mechanical push buttons	Electronic push buttons	Electronic slider
Hob ² Hood			
Fan Speed	3	4	Continuous+boost
Breeze Function			
Lights	LED	LED	LED
No. of Lamp x W	2	2	2
Charcoal Filter	2,Included	2,Included	1,Included
Charcoal Filter Type	ECFB03	ECFB02	Type 57
Ultra Charcoal Filter		Accessory	-
Ultra Charcoal Filter Type		ECFBLL01	-
Grease Filter Type	Aluminium cassette	Stainless Steel	Aluminium cassette
Ducted Maximum (ca. m ³ /h)	370	600	352
Ducted Boost (ca. m ³ /h)			
Noise (Max. Setting) Ducted (dB(A))	68	63	62
Recirculation Maximum (ca. m ³ /h)	125	350	232
Recirculation Boost (ca. m ³ /h)			
Noise (max. Setting) Recirculation (dB(A))	69	70	67
Annual Energy Consumption, kWh/annum	48,9	96,5	106,1
Energy Efficiency Class	C	C	D
Fluid Dynamic Efficiency Class	D	D	D
Lighting Efficiency Class	E	A	A
Grease Filter Efficiency	721	835	66
Grease Filter Efficiency Class	D	C	D
Off Mode Power (W)			
Stand-by Power (W)			
Installation Height (mm)			
Minimum Distance from Cooking Top ELECTRIC	50	50	50
Minimum Distance from Cooking Top GAS	65	65	70
Dimensions (mm)			
Width	598	700	598
Depth	280	285	270
Height Max	180	245	400
Height of Body	40	245	400
Other			
Air Outlet	120	150	120

DISHWASHERS



FSK93800P



FSK83700P



FSK63800P



FSK63700P

Overview				
Capacity (Number of IEC Place Settings)	13	15	13	15
XXL Tub (Large Interior)	•	•	•	•
Control Type	Touch Control	Touch Control	Electronic	Electronic
Number of Temperatures	5	5	4	4
Number of Programmes	8	8	6	6
Automatic 45°C-70°C Programme	•	•	•	•
90 Min 60°C Programme	•	•	•	•
Quickwash 60°C, 30 Min Programme	•	•	•	•
Eco Programme	•	•	•	•
Intensive advanced 70°C Programme	•	•	•	•
Maintenance Cycle	•	•	•	•
Glass 45°C Programme	•	•	•	•
Rinse and Hold Programme	•	•	•	•
Extra silent Programme	•	•	•	•
ProZone Programme	•	•	•	•
ExtraHygiene Option	•	•	•	•
TimeSaver Option	•	•	•	•
XtraDry Option	•	•	•	•
AirDry Technology (Automatic Door Opening)	•	•	•	•
Glass care, Soft Spikes	•	•	•	•
Glass care, Soft Grips	•	•	•	•
Delay Start	•	•	•	•
Time Remaining	•	•	•	•
ComfortLift®	•	•	•	•
Satellite Spray Arm	•	•	•	•
Ceiling Spray Arm	•	•	•	•
Height Adjustable Upper Basket	•	•	•	•
Foldable Plate Racks – Bottom Basket	•	•	•	•
Foldable Cup Shelves – Bottom Basket	•	•	•	•
Removable Cutlery Drawer	•	•	•	•
Moveable Cutlery Basket	•	•	•	•
Time Beam – Spotlight	•	•	•	•
Light Beam – Spotlight	•	•	•	•
Hinges	Sliding Hinges	Sliding Hinges	Sliding Hinges	Sliding Hinges
Dimensions				
Appliance dimensions				
Height	818	818	818	818
Width	596	596	596	596
Depth	550	550	550	550
Aperture dimensions				
Built-in Height	820	820	820	820
Built-in Width	900	900	900	900
Built-in Depth	600	600	600	600
Furniture door dimensions				
Door Height (Min – Max)	670-820	670-820	670-820	670-820
Door weight (Min – Max)	1.5-10	1.5-10	1.5-10	1.5-10
Performance				
Declared Programme	ECO 50	ECO 50	ECO 50	ECO 50
Energy Efficiency Class	A+++	A+++	A+++	A+++
Energy Efficiency Index	499	499	499	499
Annual Energy Consumption	241	241	241	241
Annual Water Consumption	3080	3080	3080	3080
Energy Consumption	0.857	0.857	0.857	0.857
Water Consumption	11	11	11	11
Drying Performance	A	A	A	A
Maximum Noise Level	39	42	44	44
Cleaning Performance	A	A	A	A
Programme Time (min)	225	225	225	225
Stand-by Power (W)	0.1	0.1	0.1	0.1
Off Mode Power (W)	0.1	0.1	0.1	0.1
Left-on Mode Power (W)	5	5	5	5
Left-on Mode Duration Min	5	5	5	5
Auto Switch Off (End of Programme)	•	•	•	•
Other				
Voltage	220-240	220-240	220-240	220-240
Frequency	50/60	50/60	50/60	50/60
Connected Load	1550-2200	1550-2200	1550-2200	1550-2200
Fuse Rating	10	10	10	10
Minimum Water Pressure 1 bar/15 psi	•	•	•	•
Inlet Hose with 3/4" BSP Thread Hose Connection	•	•	•	•
Water Softener	•	•	•	•
Water Supply (Max. 60 Degrees)	Cold or Hot	Cold or Hot	Cold or Hot	Cold or Hot
Salt Refill Indicator	•	•	•	•
Rinse Aid Refill Indicator	•	•	•	•
Water Hardness Setting	•	•	•	•
Top and Side Fixing Brackets	•	•	•	•
Worktop Steam Protection	•	•	•	•



FSK5260PP



FSK53600Z



FSB41600Z



FEE62600PM

Overview

Capacity (Number of IEC Place Settings)	15	13	13	13
XXL Tub (Large Interior)	•			•
Control Type	Electronic	Electronic	Electronic	Electronic
Number of Temperatures	3	4	4	4
Number of Programmes	5	5	5	6
Automatic 45°C-70°C Programme	•	•	•	•
90 Min 60°C Programme				
Quickwash 60°C, 30 Min Programme	•	•	•	•
Eco Programme	•	•	•	•
Intensive advanced 70°C Programme	•	•	•	•
Maintenance Cycle				
Glass 45°C Programme	•	•		•
Rinse and Hold Programme			•	
Extra silent Programme				•
ProZone Programme				
ExtraHygiene Option				•
TimeSaver Option	•	•		•
XtraDry Option	•	•	•	•
AirDry Technology (Automatic Door Opening)	•	•	•	•
Glass care, Soft Spikes	•	•		•
Glass care, Soft Grips	•	•		•
Delay Start	•	•	•	•
Time Remaining	•	•	•	•
ComfortLift®				
Satellite Spray Arm	•			•
Ceiling Spray Arm	•			•
Height Adjustable Upper Basket	•	•	•	•
Foldable Plate Racks – Bottom Basket	•	•	•	•
Foldable Cup Shelves – Bottom Basket	•	•	•	•
Removable Cutlery Drawer	•			
Moveable Cutlery Basket		•	•	•
Time Beam – Spotlight				
Light Beam – Spotlight	•	•		
Hinges	Sliding Hinges	Sliding Hinges	Sliding hinges	Double Fulcrum

Dimensions

Appliance dimensions				
Height	818	818	818	818
Width	596	596	596	596
Depth	550	550	550	575
Aperture dimensions				
Built-in Height	820	820	820	820-900
Built-in Width	900	880	880	600
Built-in Depth	600	600	600	570
Furniture door dimensions				
Door Height (Min – Max)	670-820	645-776	645-776	570-655
Door weight (Min – Max)	1.5-10	2.0-10	2.0-10.0	1.5-8.0

Performance

Declared Programme	ECO 50	ECO 50	ECO 50	ECO 50
Energy Efficiency Class	A++	A+++	A+	A++
Energy Efficiency Index	55.9	49.9	62.9	55.9
Annual Energy Consumption	262	234	295	262
Annual Water Consumption	2860	2775	2775	2940
Energy Consumption	0.932	0.832	1.05	0.921
Water Consumption	10.2	9.9	9.9	10.5
Drying Performance	A	A	A	A
Maximum Noise Level	46	44	47	44
Cleaning Performance	A	A	A	A
Programme Time (min)	225	240	240	233
Stand-by Power (W)	0.1	0.1	0.1	0.1
Off Mode Power (W)	0.1	0.1	0.1	0.1
Left-on Mode Power (W)	5	5	5	5
Left-on Mode Duration Min	5	5	5	5
Auto Switch Off (End of Programme)	•	•	•	•

Other

Voltage	220-240	220-240	220-240	220-240
Frequency	50/60	50/60	50/60	50
Connected Load	1550-2200	1550-2200	1550-2200	1950
Fuse Rating	10	10	10	10
Minimum Water Pressure 1 bar/15 psi	•	•	•	•
Inlet Hose with 3/4" BSP Thread Hose Connection	•	•	•	•
Water Softener	•	•	•	•
Water Supply (Max. 60 Degrees)	Cold or Hot	Cold or Hot	Cold or Hot	Cold or Hot
Salt Refill Indicator	•	•	•	•
Rinse Aid Refill Indicator	•	•	•	•
Water Hardness Setting	•	•	•	•
Top and Side Fixing Brackets	•	•	•	•
Worktop Steam Protection	•	•	•	•

DISHWASHERS



FSK73400P

Overview

Capacity (Number of IEC Place Settings)	9
XXL Tub (Large Interior)	
Control Type	Electronic
Number of Temperatures	4
Number of Programmes	7
Automatic 45°C-70°C Programme	•
90 Min 60°C Programme	
Quickwash 60°C, 30 Min Programme	•
Eco Programme	•
Intensive advanced 70°C Programme	•
Maintenance Cycle	
Glass 45°C Programme	•
Rinse and Hold Programme	
Extra silent Programme	•
ProZone Programme	•
ExtraHygiene Option	•
TimeSaver Option	•
XtraDry Option	•
AirDry Technology (Automatic Door Opening)	•
Glass care, Soft Spikes	•
Glass care, Soft Grips	
Delay Start	•
Time Remaining	•
ComfortLift®	
Satellite Spray Arm	•
Ceiling Spray Arm	•
Height Adjustable Upper Basket	•
Foldable Plate Racks – Bottom Basket	•
Foldable Cup Shelves – Bottom Basket	•
Removable Cutlery Drawer	
Moveable Cutlery Basket	•
Time Beam – Spotlight	•
Light Beam – Spotlight	
Hinges	Sliding hinges

Dimensions**Appliance dimensions**

Height	818
Width	446
Depth	550

Aperture dimensions

Built-in Height	820-900
Built-in Width	450
Built-in Depth	550

Furniture door dimensions

Door Height (Min – Max)	645-776
Door weight (Min – Max)	2.0-6.0KG

Performance

Declared Programme	ECO 50
Energy Efficiency Class	A+++
Energy Efficiency Index	499
Annual Energy Consumption	176
Annual Water Consumption	2775
Energy Consumption	0.625
Water Consumption	99
Drying Performance	A
Maximum Noise Level	44
Cleaning Performance	A
Programme Time (min)	240
Stand-by Power (W)	0.1
Off Mode Power (W)	0.1
Left-on Mode Power (W)	5
Left-on Mode Duration Min	5
Auto Switch Off (End of Programme)	•

Other

Voltage	220-240
Frequency	50/60
Connected Load	1550-2200
Fuse Rating	10
Minimum Water Pressure 1 bar/15 psi	•
Inlet Hose with 3/4" BSP Thread Hose Connection	•
Water Softener	•
Water Supply (Max. 60 Degrees)	Cold or Hot
Salt Refill Indicator	•
Rinse Aid Refill Indicator	•
Water Hardness Setting	•
Top and Side Fixing Brackets	•
Worktop Steam Protection	•

WASHING MACHINES



L9FEC946R



L8FEC866R



L7FEE845R



L7FC8432BI

Overview

Wash Capacity (kg)	9	8	8	8
Spin Speed (rpm)	1400	1600	1400	1400
Display	Large display		Medium display	Medium display
Controls	Dial and touch buttons	Dial and touch buttons	Dial and touch buttons	Dial and touch buttons
Fascia Panel	Stainless steel fascia	Stainless steel fascia	Matte silver fascia	White fascia pannel
Door Colour/Type	Premium silver door	Premium silver door	Premium silver door	Premium silver door

Technology

9000 Series Technology	•			
8000 Series Technology	•	•		
7000 Series Technology	•	•	•	•
6000 Series Technology	•	•	•	•

Awards

Product of the Year	•			
Woolmark		GREEN	GREEN	BLUE
P&G	GREEN	Premium	Standard	BLUE
Quiet Mark	•	•	•	•

Programmes

Cottons	•	•	•	•
Cotton Eco				•
Synthetics	•	•	•	•
Delicates	•	•	•	•
Wool	•	•	•	
Wool/Silk				•
Wool Plus				
ColourPro	•			
OKOPower	•	•		
Steam	•	•	•	•
Refresh				
Quick 20min 3kg	•	•	•	•
Cotton 20				
Mix 20				
Easy Iron				
Duvet		•	•	•
Jeans/Denim				•
Sports			•	•
Sport Intensive				
Rinse				•
Anti-Allergy	•	•	•	•
Outdoor	•	•	•	•
Spin/Drain				•

Options

Delay Start	•	•	•	•
Soft Plus	•	•	•	•
Temperature Selection	•	•	•	•
Spin Selection	•	•	•	•
Start/Pause	•	•	•	•
Plus Steam	•	•	•	•
Stains/Prewash	•	•	•	•
Rinse	•	•	•	•
Extra Rinse	•	•	•	•
Time Save	•	•	•	•
Economy	•	•	•	•
Child Lock	•	•	•	•

Energy and Water Performance

Energy Efficiency Class	A+++	A+++	A+++	A+++
Wash Performance	A	A	A	A
Spin Performance	B	A	B	B
Annual Energy Consumption (kWh)	65	97	137	180
Annual Water Consumption (L)	10499	10999	10999	11400
Washing Noise (dB)	47	47	51	51
Spinning Noise (dB)	73	75	75	77
Stand-by Power (W)	1	1	1	1

Programme Performance*

Load (kg)	9	8	8	8
Energy (kWh)	0.29	0.46	0.68	0.9
Water (L)	55	55	54	57
Duration (mins)	258	247	228	280

*Standard cotton cycle 60°C, full load.

Dimensions

Height (mm)	850	850	850	820
Width (mm)	600	600	600	596
Depth Max (mm)	660	600	600	555
Net Weight (kg)	78.5	73.5	70.5	76.5
Power Cord Length (mm)	1500	1500	1500	1500
Length of Waste Pipe (mm)	1450	1450	1450	

TUMBLE DRYERS



T8DEC846R



T7DEE835R

Overview		
Dry Capacity (kg)	8	8
Display	Large display	Medium display
Controls	Dial and touch buttons	Dial and touch buttons
Fascia Panel	Stainless steel fascia panel	Matte silver fascia panel
Door Colour/Type	Premium silver door	Premium silver door
Technology		
8000 Series Technology	•	
7000 Series Technology	•	•
6000 Series Technology	•	•
Awards		
Woolmark	BLUE	
Quiet Mark		
Programmes		
Cottons	•	•
Cotton Eco		
Synthetics	•	•
Refresh		
Delicates		
Wool	•	•
Wool Refresh		
Mixed	•	•
Silk	•	•
Bedlinen	•	•
Easy Iron	•	•
Outdoor	•	
Duvet	•	•
Sports	•	•
Active Wear		•
Jeans		
Freshen Up		
Time 30		
Cottons – Extra Dry		
Cottons – Strong Dry		
Cottons – Cupboard Dry		
Cottons – Iron Dry		
Synthetics – Extra Dry		
Synthetics – Cupboard Dry		
Synthetics – Iron Dry		
Options		
Delay Start	•	•
Delicate		
Drying Mode		
Anti-crease	•	•
Dryness Level	•	•
Time Drying	•	•
Start/Pause	•	•
Child Lock	•	•
Quiet	•	
Steam Level		
Sensitive		
Buzzer		
Refresh	•	•
Energy Performance		
Energy Efficiency Class	A++	A+
Annual Energy Consumption (kWh)	235	309
Drying Noise (dB)	66	66
Stand-by Power (W)	19	19
Dimensions		
Height (mm)	850	850
Width (mm)	600	600
Depth Max (mm)	665	665
Net Weight (kg)	48.26	48.46
Power Cord Length (mm)	1450	1450

WASHER DRYERS



L7WEE965R



L7WBG741R



L7WC8632BI

Overview

Wash Capacity (kg)	9	7	8
Dry Capacity (kg)	6	4	4
Spin Speed (rpm)	1600	1400	1600
Display	Medium display	Small Display	Medium Display
Controls	Dial and touch buttons	Dial and touch buttons	Dial and touch buttons
Fascia Panel	Matte silver fascia panel	White fascia panel	Silver fascia panel
Door Colour/Type	Premium silver door	Premium white door	Premium white door

Technology

9000 Series Technology			
8000 Series Technology			
7000 Series Technology	•	•	•

Awards

Woolmark (across wash and dry cycles)	BLUE	BLUE	
---------------------------------------	------	------	--

Programmes

Cottons	•	•	•
Cotton Eco	•	•	•
Synthetics	•	•	•
Delicates	•	•	•
Wool/Silk			
Sports			•
Steam	•	•	•
Wool/Handwash	•	•	•
Outdoor	•	•	•
NonStop 3h/3kg			
NonStop OKOPower			
NonStop 60min	•	•	•
Rinse	•	•	•
Spin/Drain			•
Anti-Allergy			•
Denim			•
Machine Clean			•

Options

Anti-Allergy	•		•
Temperature Selection	•	•	•
Spin Selection	•		•
Prewash	•	•	•
Stains			•
Delay Start	•	•	•
Anti-crease			•
Extra Rinse			•
Quick Wash	•	•	
Wash/Dry mode	•	•	•
Time Drying	•	•	•
Auto Drying			•
Start/Pause	•	•	•
Child Lock	•	•	•

Energy and Water Performance

Energy Efficiency Class	A	A	A
Wash Performance	A	A	A
Annual Energy Consumption (kWh) Washing Only	170	118	TBC*
Annual Water Consumption (L) Washing Only	11200	10400	TBC*
Annual Energy Consumption (kWh) Washing and Drying	1212	938	TBC*
Annual Water Consumption (L) Washing and Drying	19800	18400	TBC*
Washing Noise (dB)	51	51	TBC*
Spinning Noise (dB)	77	76	TBC*
Drying Noise (dB)	63	59	TBC*
Stand-by Power (W)	1	1	1

Programme Performance*

Load (kg)	9	7	8
Energy (kWh)	0.85	0.59	TBC*
Water (L)	56	52	TBC*
Duration (mins)	295	262	TBC*

*Standard cotton cycle 60°C, full load.

Dimensions

Height (mm)	850	850	820
Width (mm)	600	600	596
Depth Max (mm)	660	576	555
Net Weight (kg)	75.5	66.5	69.5
Power Cord Length (mm)	1800	1800	1500
Length of Waste Pipe (mm)	1400	1400	TBC*

*To be confirmed when product is released in September 2018.

INSTALLATION DIAGRAMS

AEG has always been committed to supporting its retail partners and professional installers by providing them with best in class installation solutions. AEG kitchens are simple to install and use only one Torx T20 screwdriver to install all of our appliances, allowing installers to save time. In 2018, AEG launched a first of its kind Installer App, giving professional installers access to installation information at their fingertips.

IN THIS SECTION

Refrigeration

Integrated Fridge Freezers	196
Integrated Fridges/Freezers	197
Side by Side Fridge Freezers	198
Wine Cooling	198

Cooking

Single Ovens	199
Double Ovens	199
Compact Ovens	200
Microwave Ovens	200
Bean to Cup Coffee Machine	201
Hobs	202-208
Hoods	209-211
Warming Drawers	212
Vac Sealers	213

Dishwashers

Fully Integrated	214
Slim line Integrated	214
Semi-Integrated	214

Laundry

Built-in	214
----------	-----



ONE TORX T20
SCREWDRIVER
TO INSTALL ALL
APPLIANCES



Only **one** Torx T20 screwdriver
to install **all** appliances



Not having to change tools
saves time



Electrolux is the first manufacturer
to design an **installation app***
specifically for professional installers



*The app is available for download
on Apple and Android mobile phones.

INTEGRATED FRIDGE FREEZERS

SCE8186VTC, SCE8182VNC, SCE8182XNC

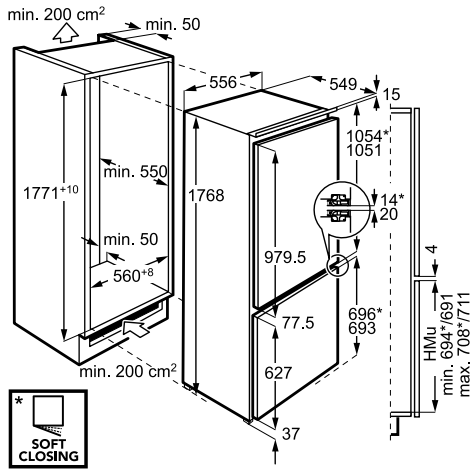

SCE8192VTS, SCE8191VTS

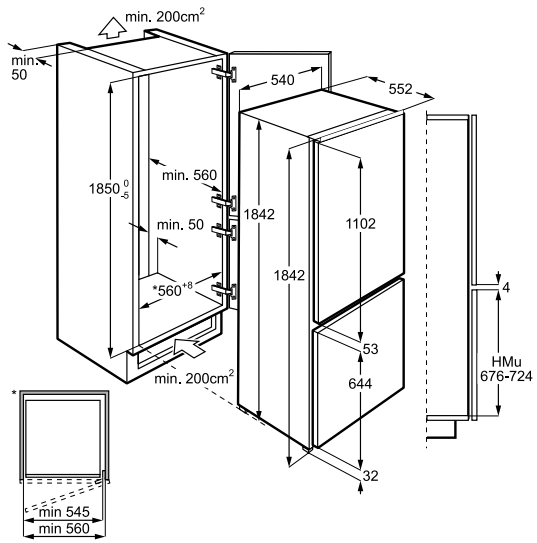

SCE8182VTS, SCE8181VTS, SCB6181XLS

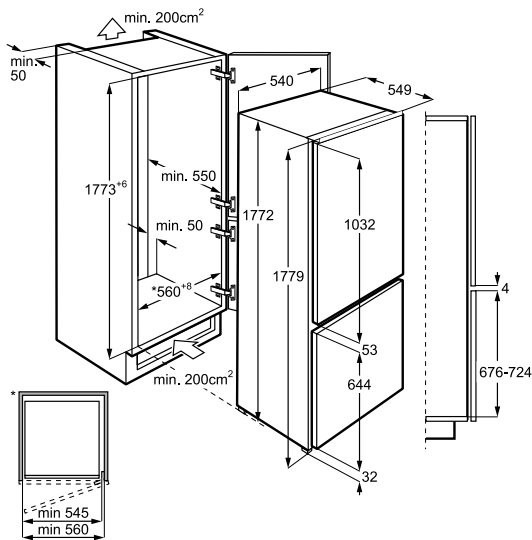

SCE8182XTS, SCE8181VNS, SCB6181VLS

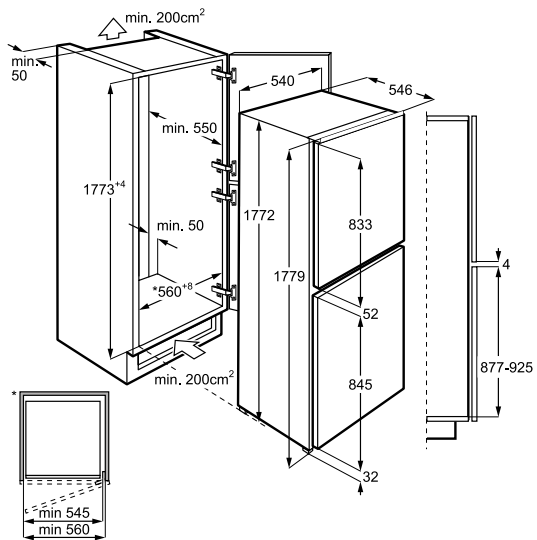

SCE81925TS

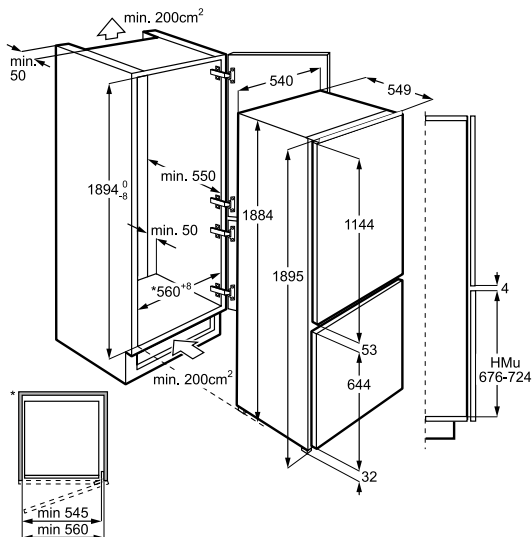

SCB5142VLS

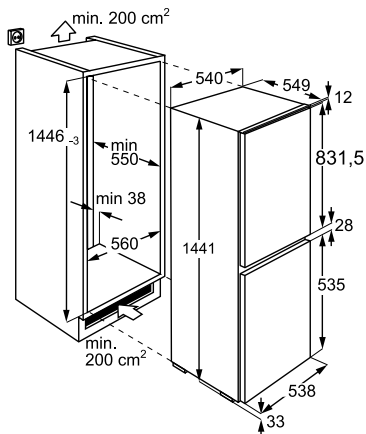

INTEGRATED FRIDGES/FREEZERS

ABE6821VNF, ABE6822VAF, ABB6821VAF, SFE5822VAF, SFB5821VAF, SKE5822VAF, SKB5821VAF



ABB8121VNF, SKE8122VAC, SKB8121VAF



ABK8182VNC, SKK8182VDC

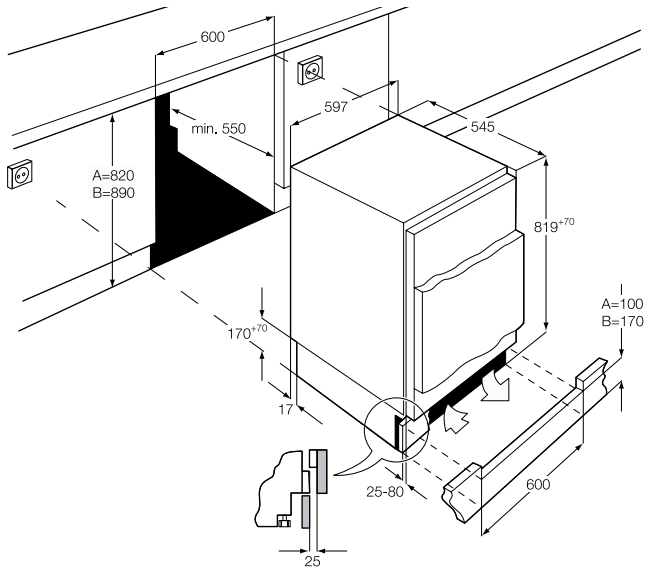
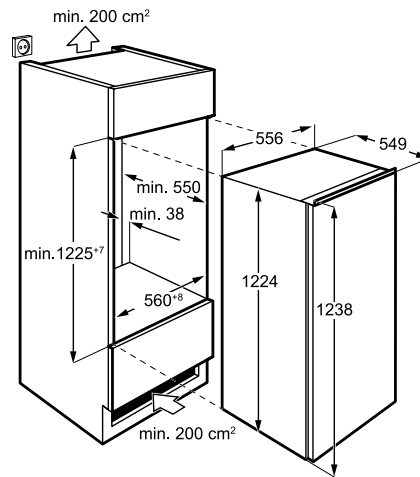
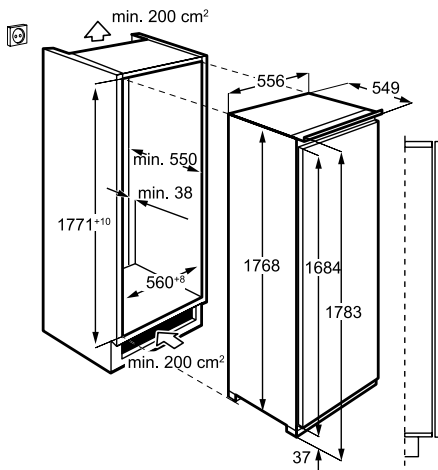

ABE6882VLS



ABB8181VNC, ABE8122VNC, SKK8182VZC, SFE8182VDC, SKB8181VDC



SFE6881VAS, SKE6881VAS

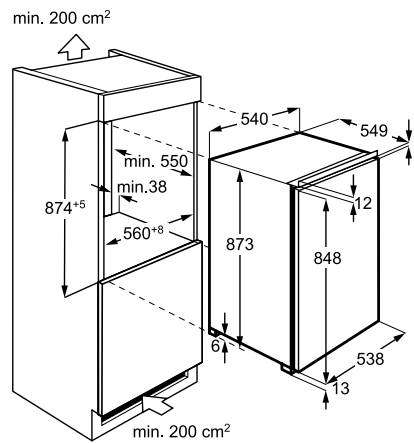
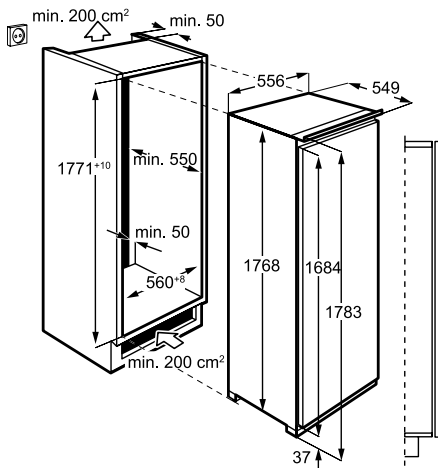
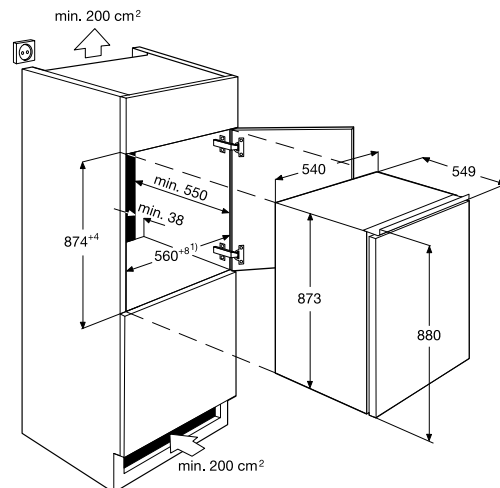

SIDE BY SIDE FRIDGE FREEZERS

RMB76111NX

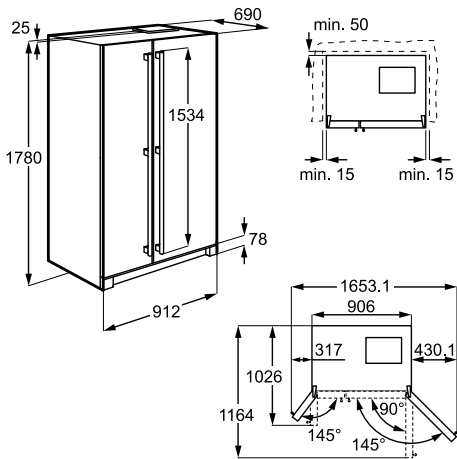

RMB76311NX

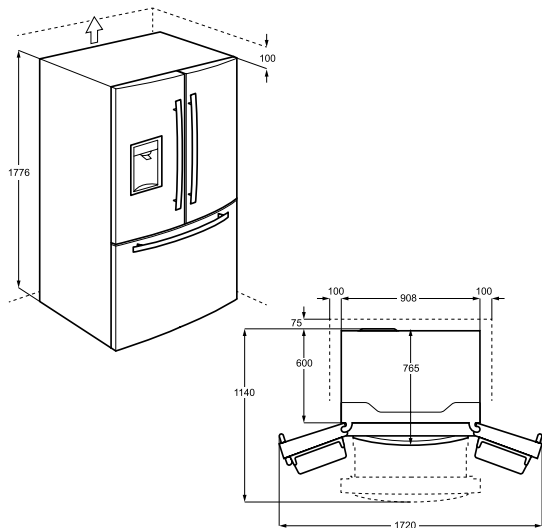

WINE COOLING

SWE66001DG

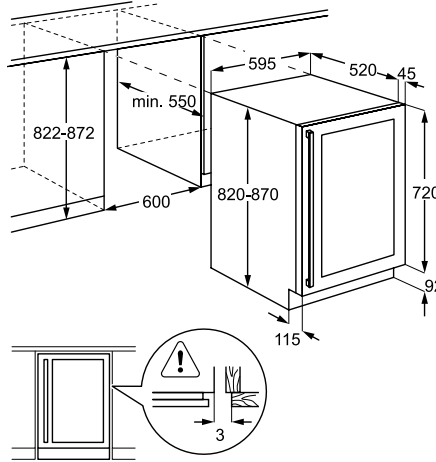

SWE63001DG

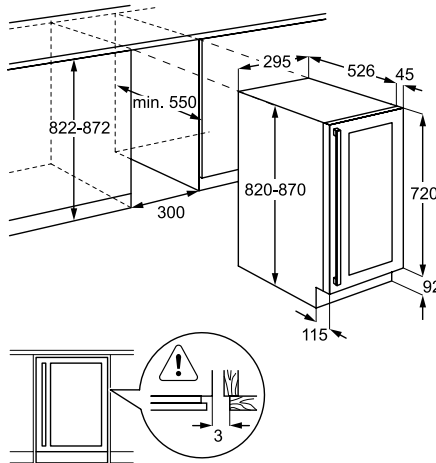

SWE61501DG

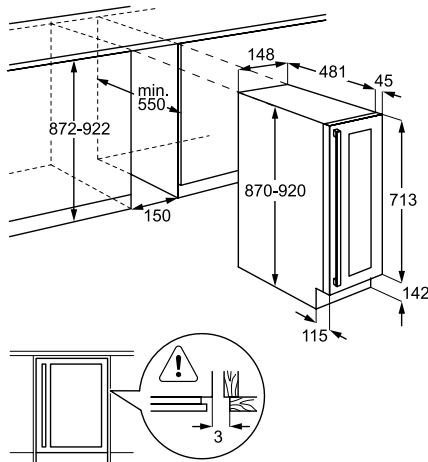

SINGLE OVENS

ALL MODELS

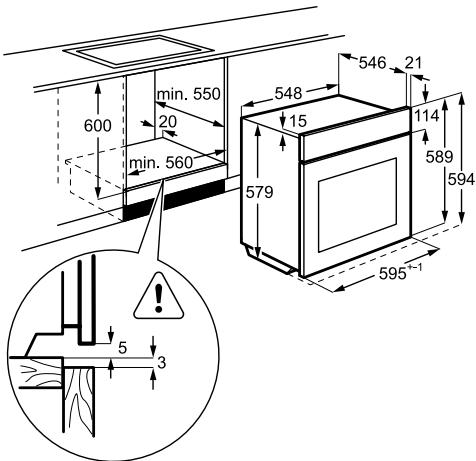

- ** Ovens with glass front
- ** Ovens with metal front

KEK442910M 90CM WIDE

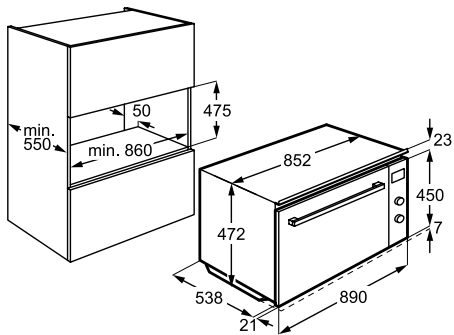

DOUBLE OVENS

ALL MODELS BUILT-IN

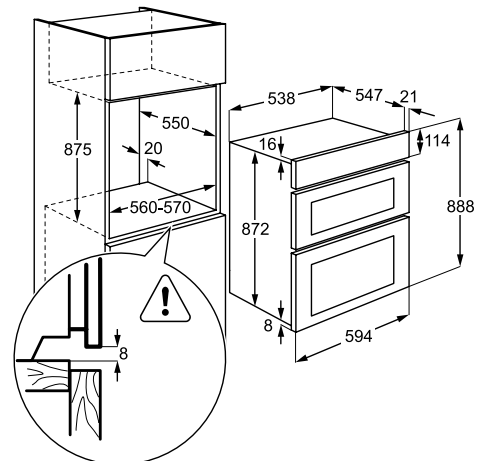

ALL MODELS BUILT UNDER

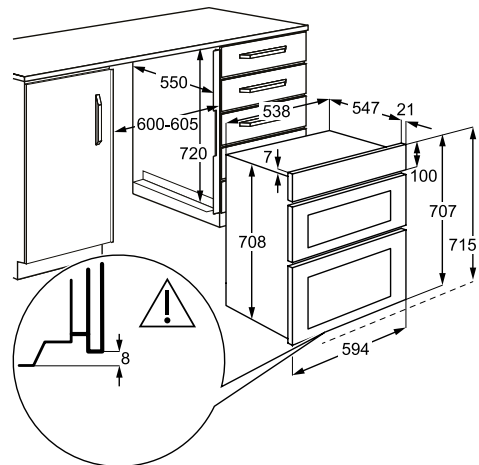

COMPACT OVENS

ALL MODELS
EXCLUDING COFFEE MACHINE

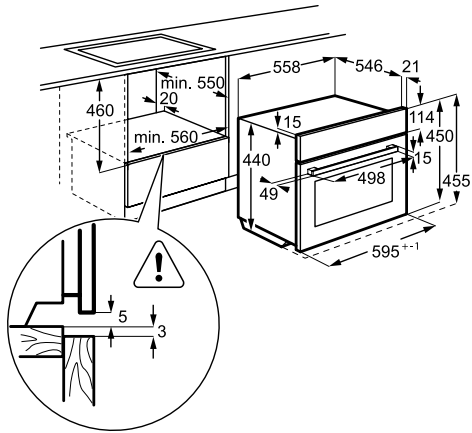

** Appliance with glass front

** Appliance with metal front

MICROWAVE OVENS

MBE2658D-M, MBE2658S-M

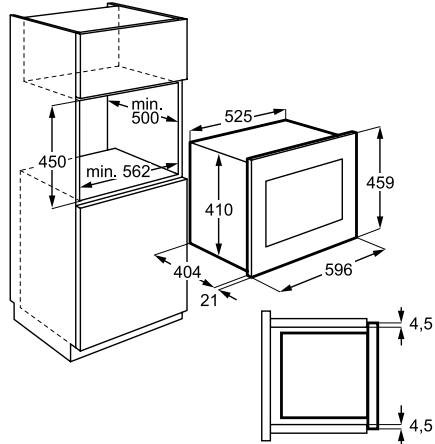

MBB1756D-M, MBB1756S-M, MBB1755S-M

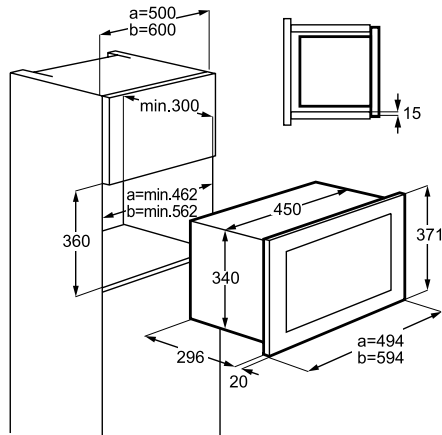

BEAN TO CUP COFFEE MACHINE

ALL MODELS

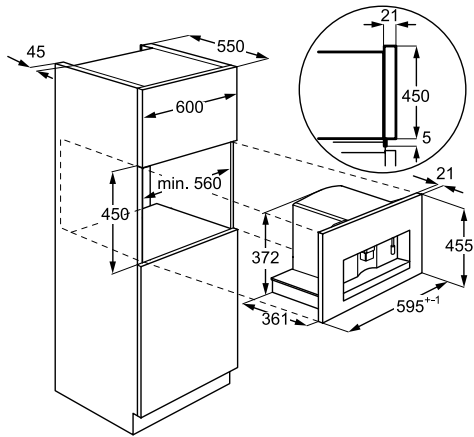

ELECTRIC HOBS

IAE84850FB

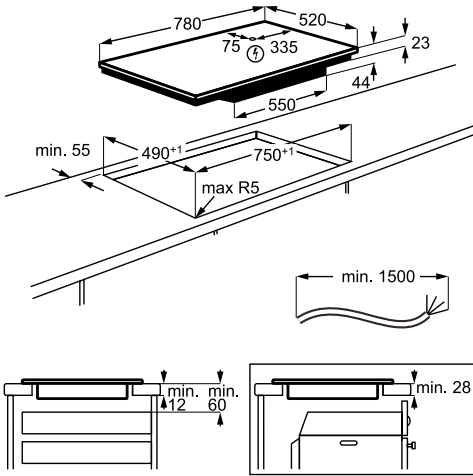

HKH81700FB

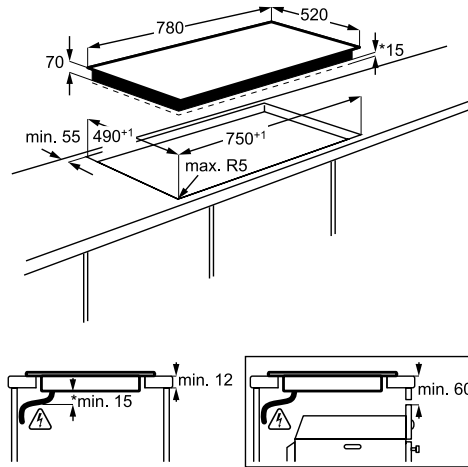

IKE85651FB

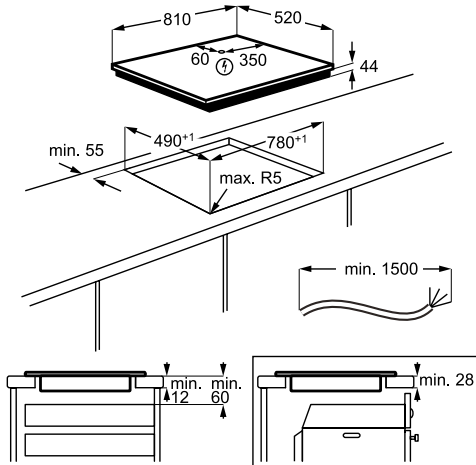

**IKE84471FB, IKE85431FB, IKB84431FB,
IKE84441FB, IKB84401FB, IKE74451FB**

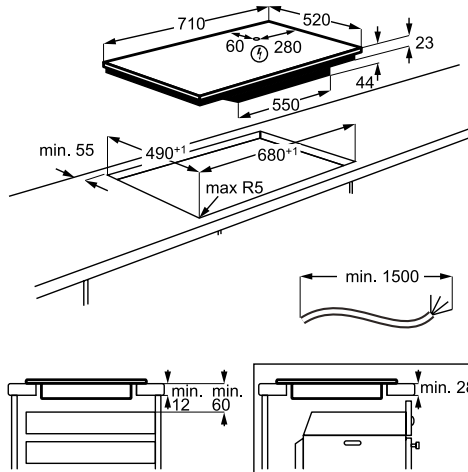

HKP87420FB, HK874400FB

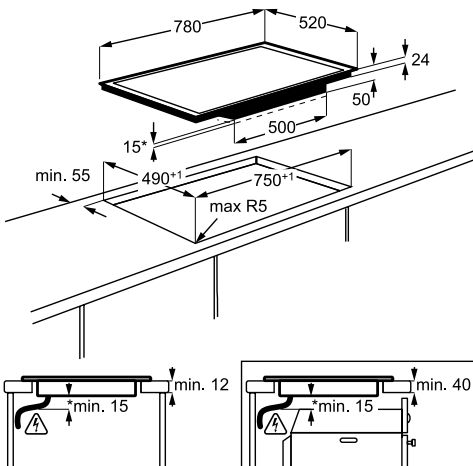

**IAE64850FB, IKE64651FB, IKE64471FB,
IKE64441FB, IKB64431FB, IKB64401FB**

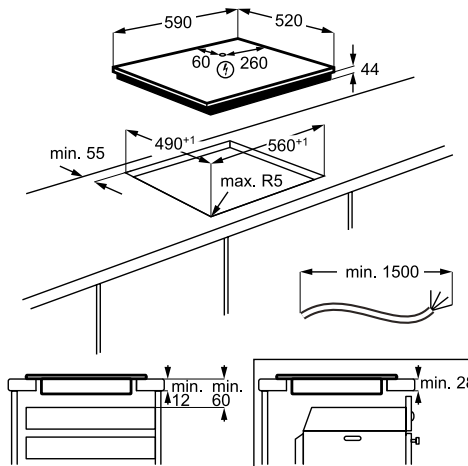

HKP67420FB

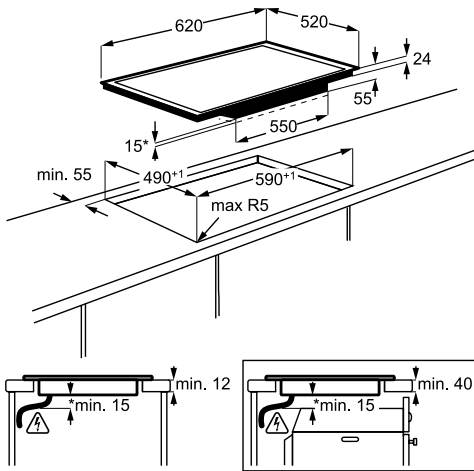

HK604200IB

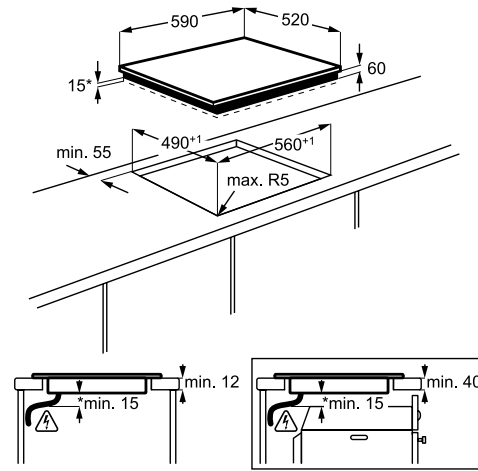

HK674400FB

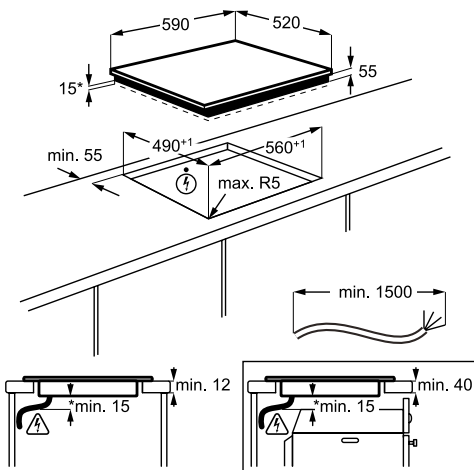

IKE95471FB

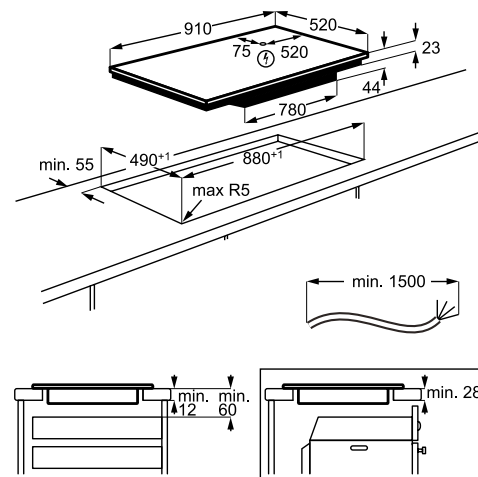

IKE64450XB, IKB64301XB

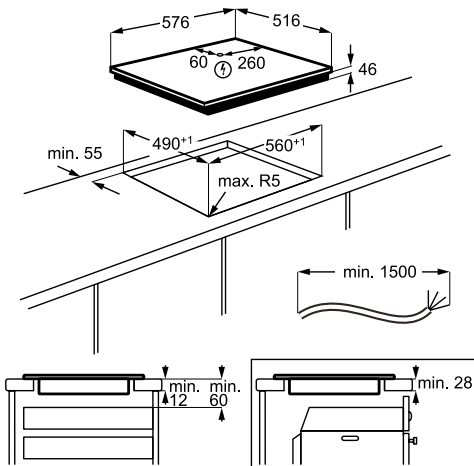

IKK93431FB

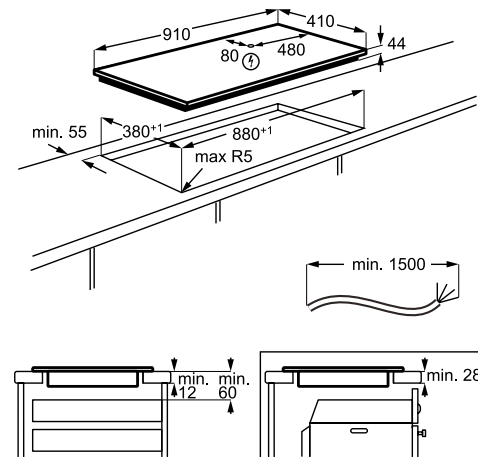

ELECTRIC HOBS

HK955070FB

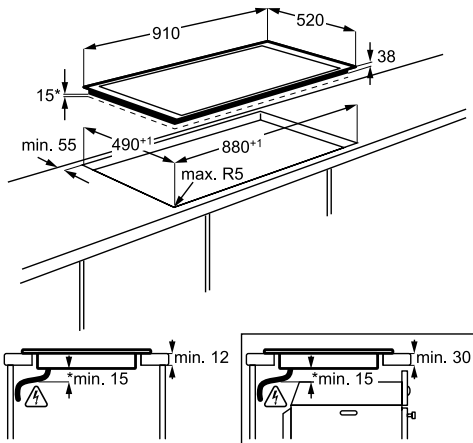

HK634060XB

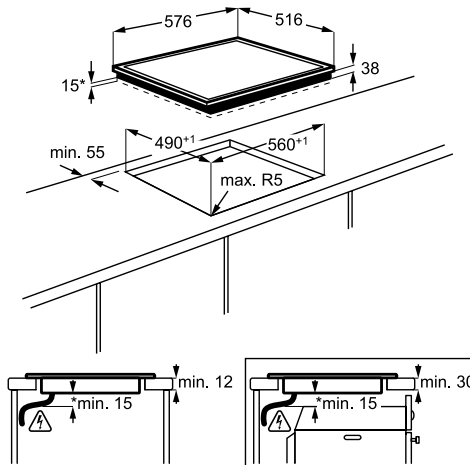

HK854080FB

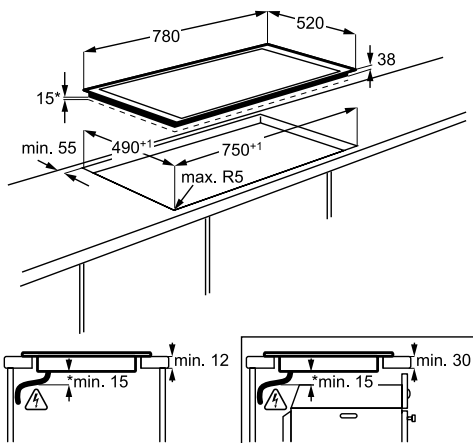

HK624010FB

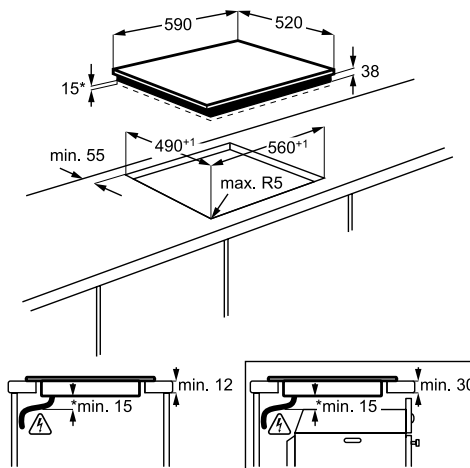

HK764070FB

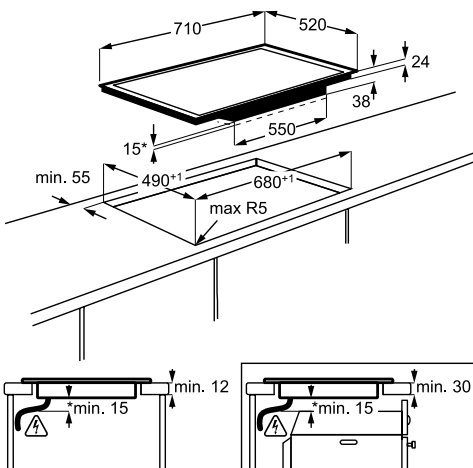

HK614000CB

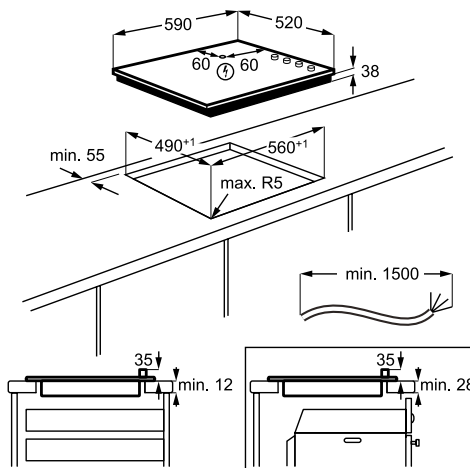

GAS HOBS

HVB95450IB

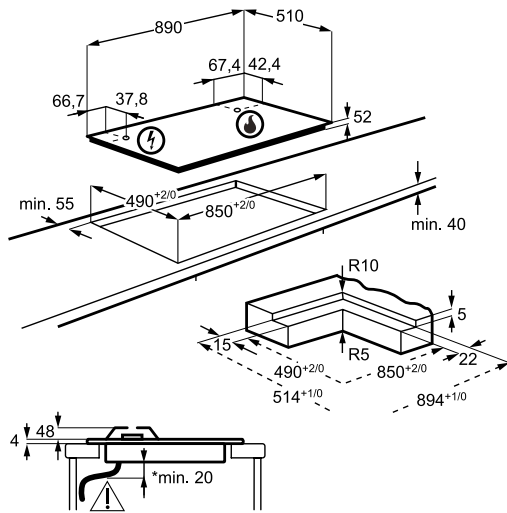

HVB75450IB

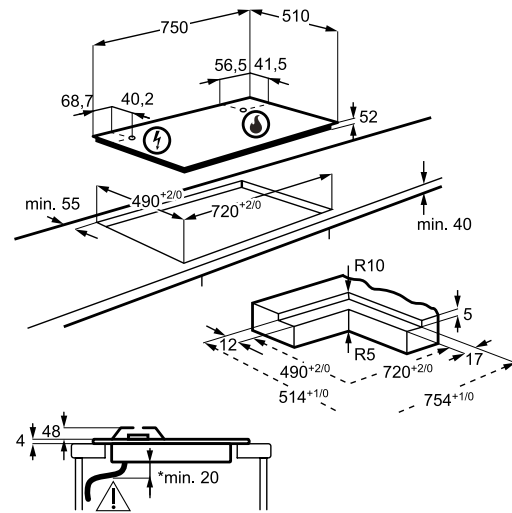

HKB95540NB

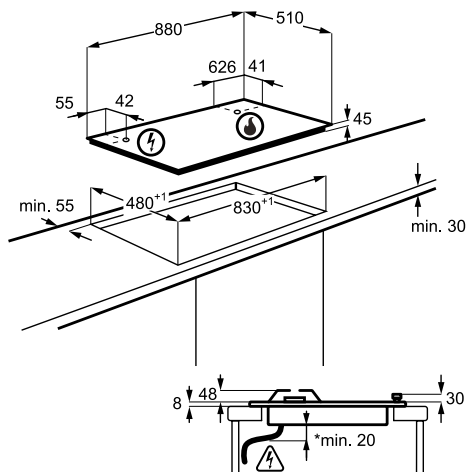

HG795840NB, HG755820UM

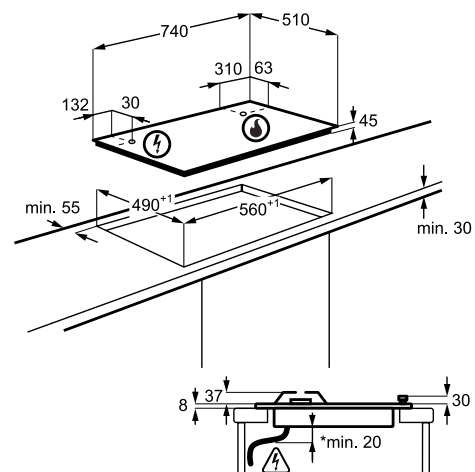

HG956440SM

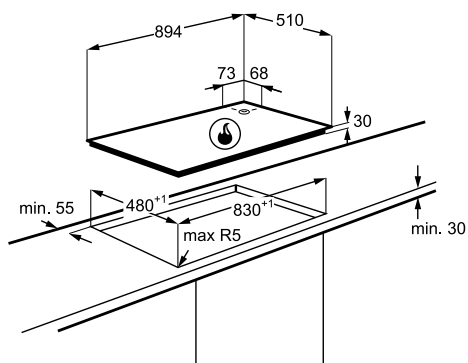

HKB75540NB

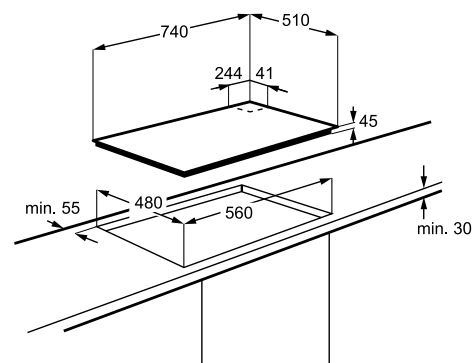

GAS HOBS

HG775450VB

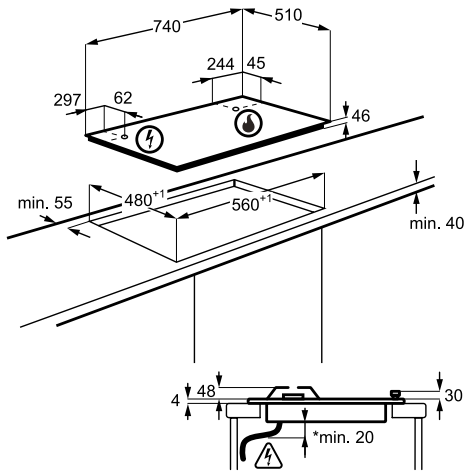

HG694840NB

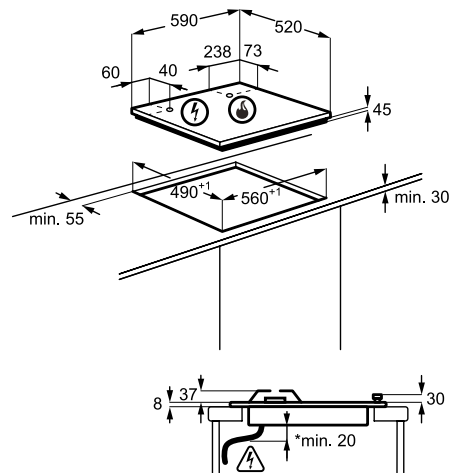

HG755521UM, HG755421UM

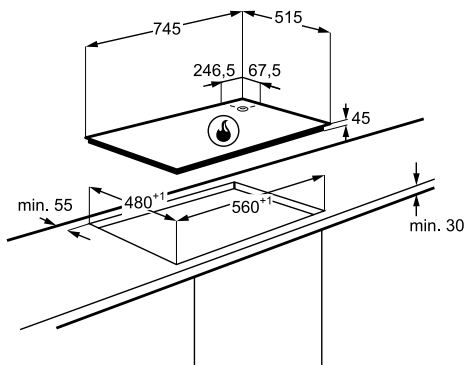

HG654820UM

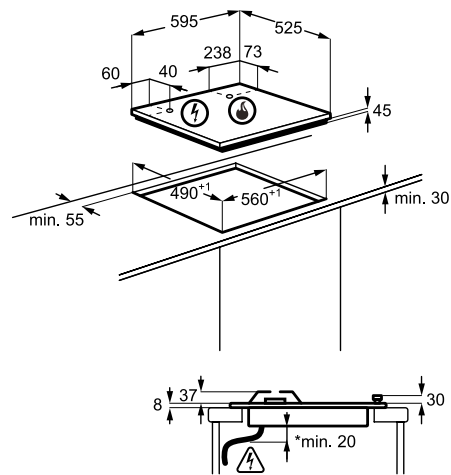

HG755551SY, HG755450SY, HG745451SM

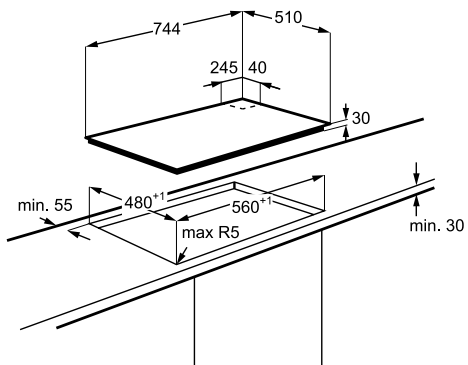

HG674550VB, HG795550XB

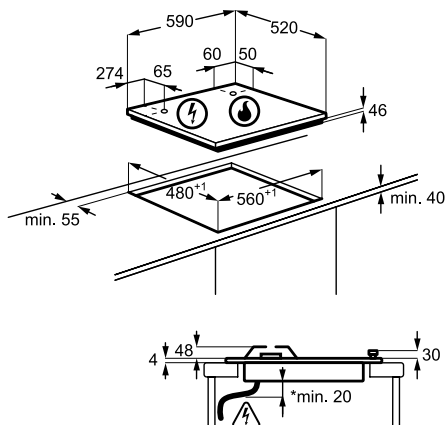

HG795450XB, HG694550XB

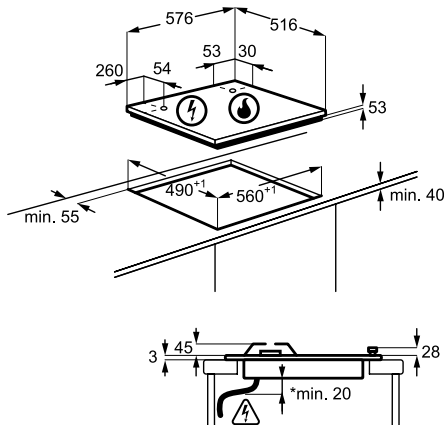

HD955100NB

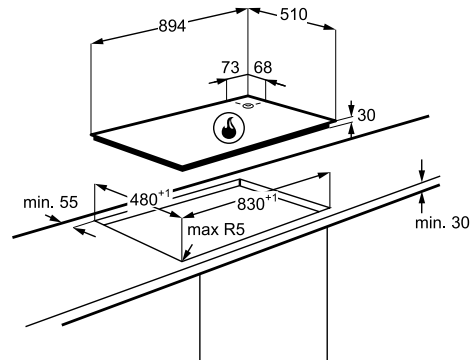

HG654421UM

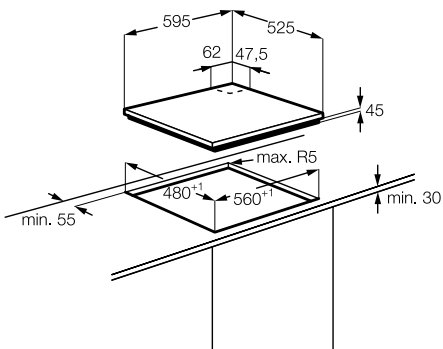

HD634170NB

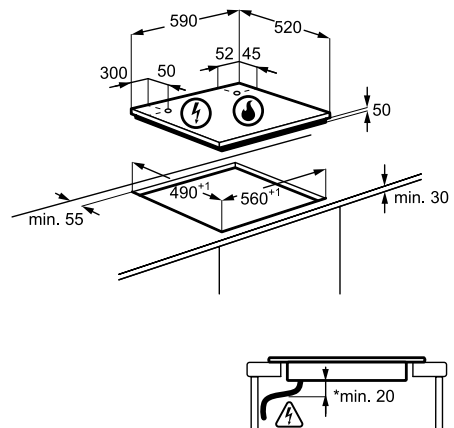

HG654550SY, HG654351SM, HG644351SM

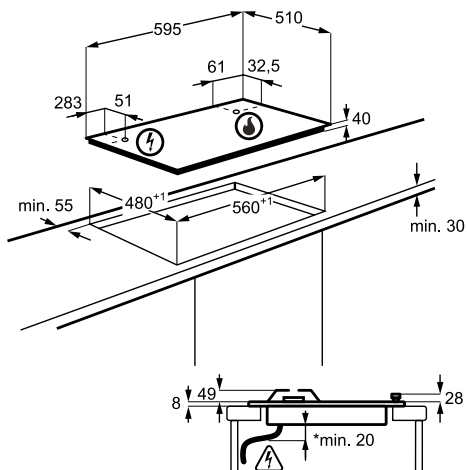

COMBOHOB

ALL MODELS

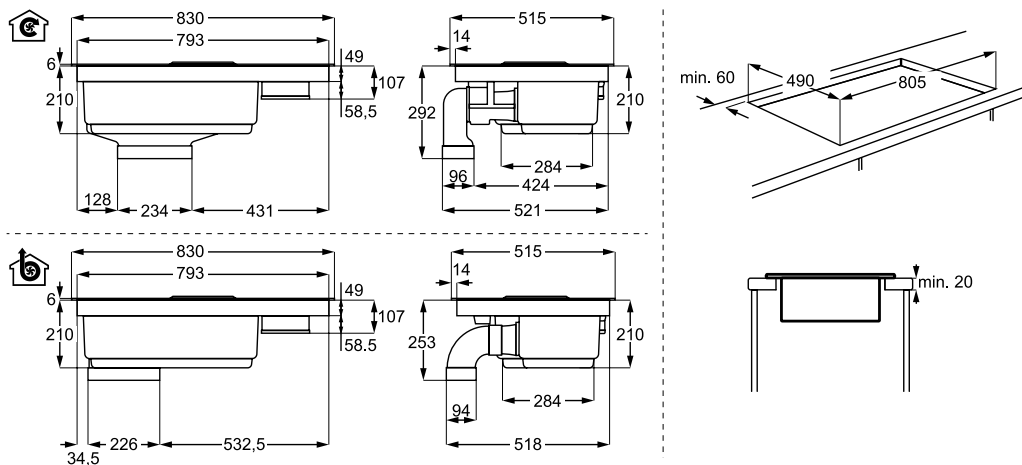

HOODS

DVK6980HB, DVK6680HB

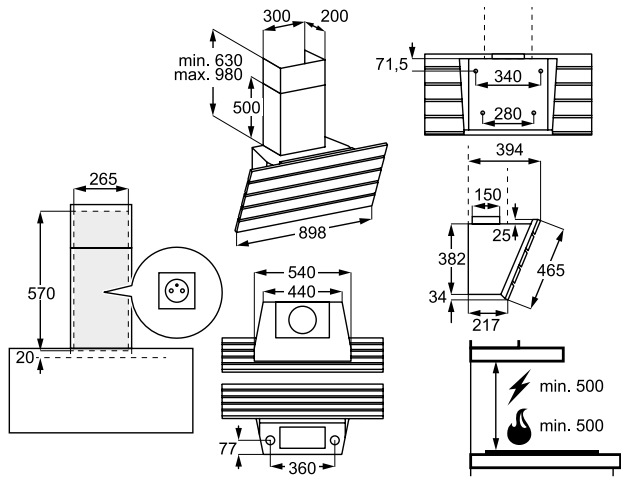

DBK7990HG

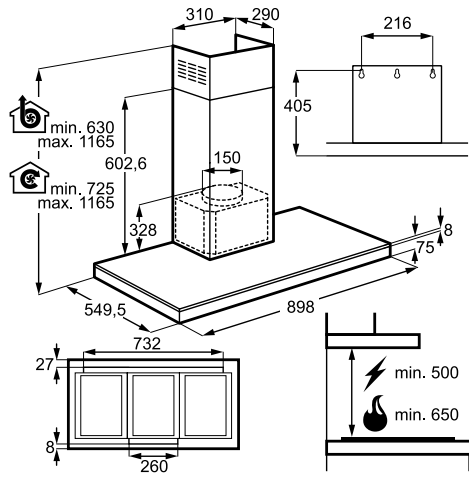

DVB4850B, DVB4550B

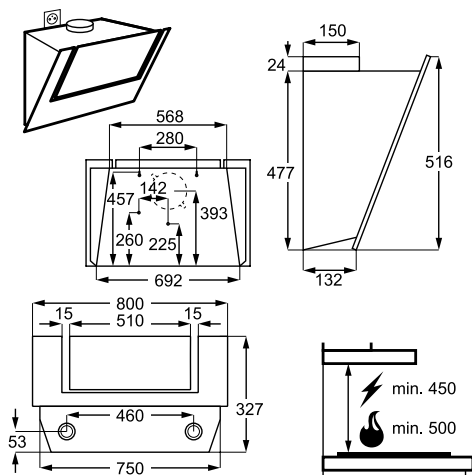

DBE6980HM, DBE6780HM, DBE6680HM

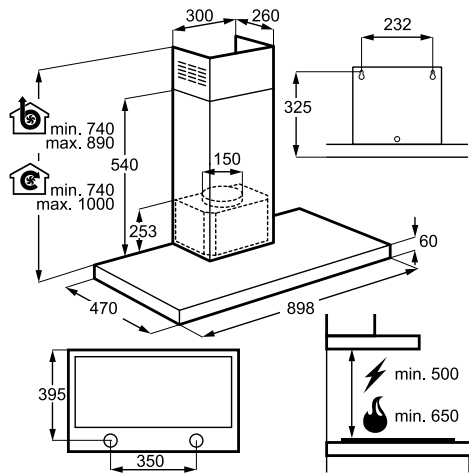

DVB4850M, DVB4550M

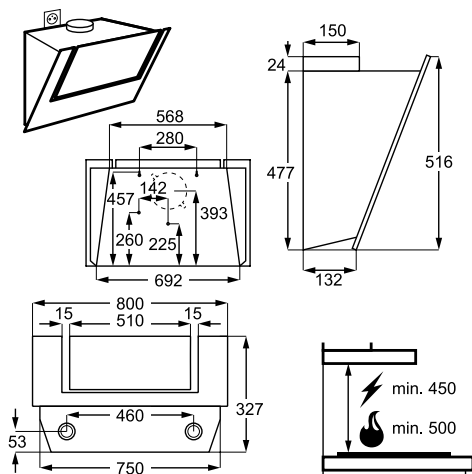

DBB5960HM, DBB5760HM, DBB5660HM

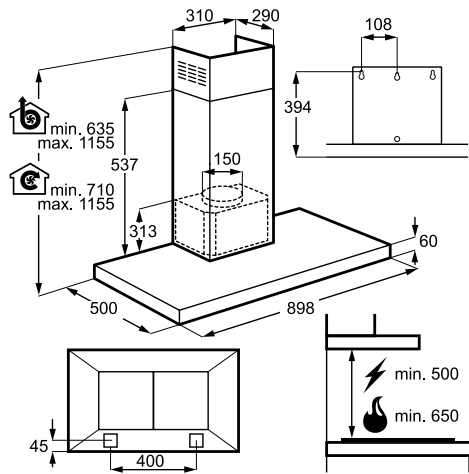

WARMING DRAWERS

KDK912922M

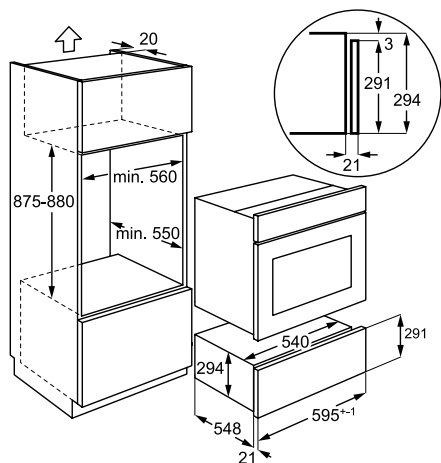

KDE911422B
BLACKLINE

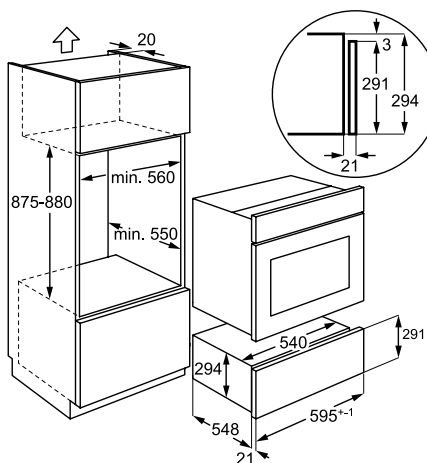

KDE912922M
29CM

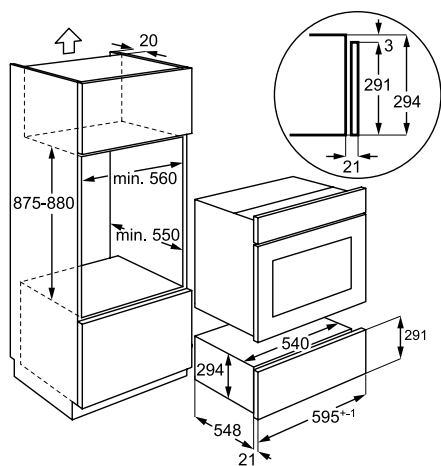

KD91405M

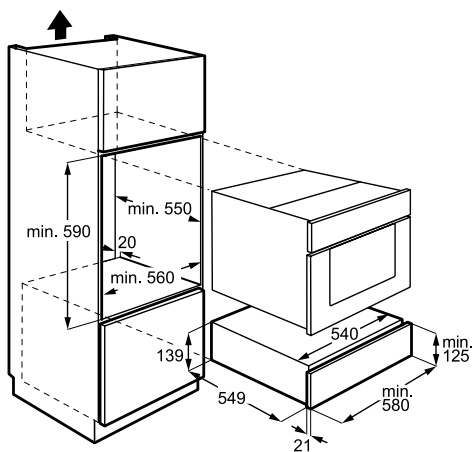

KDK911422M, KDE911422M

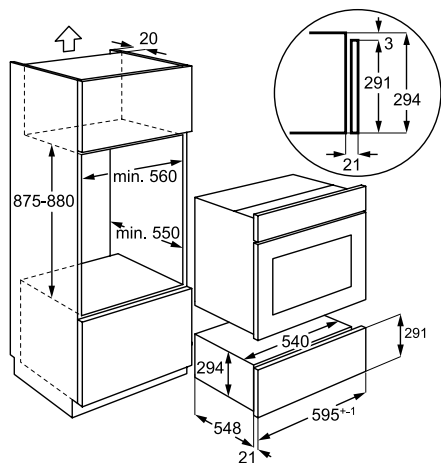

VAC SEALERS

KDK911423M, KDE911423M

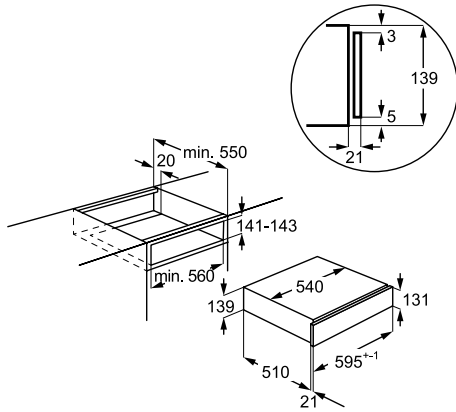

KDE911423B
BLACKLINE

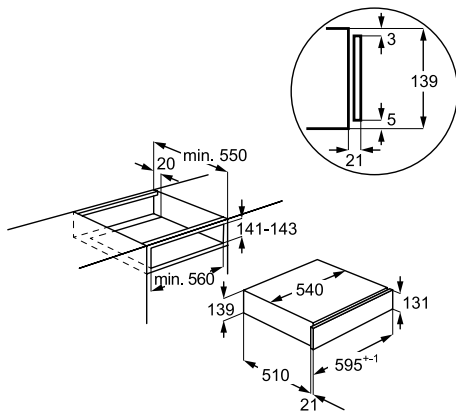

DISHWASHERS

FSK93800P FULLY INTEGRATED

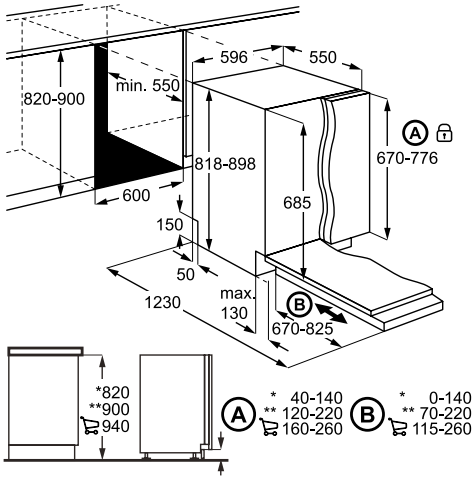

ALL MODELS SLIM LINE INTEGRATED

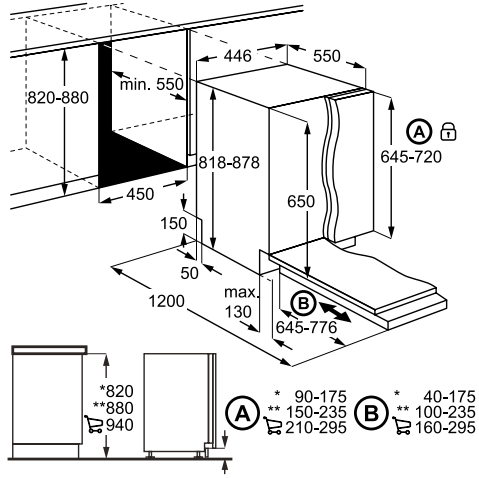

FSB41600Z FULLY INTEGRATED

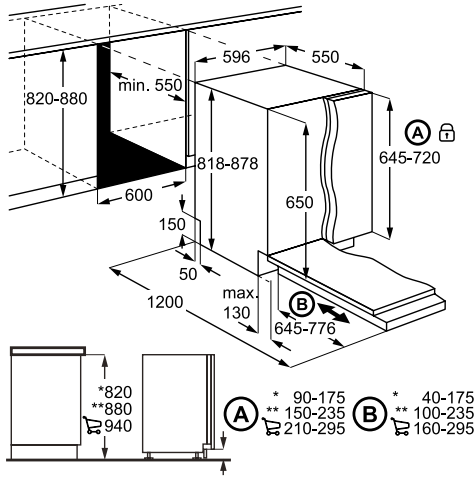

ALL MODELS SEMI-INTEGRATED

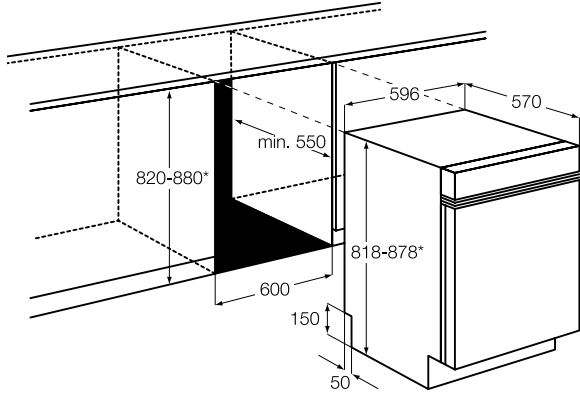

LAUNDRY BUILT-IN

L7FE7261BI, L7WE7631BI

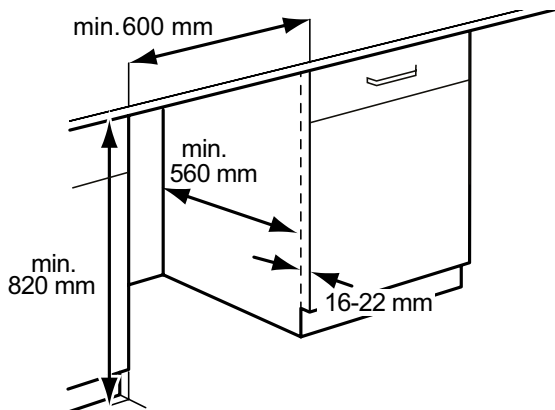

WARRANTIES

All appliances featured in the AEG Premier Partner Core Range as featured in this brochure are covered by an extended 5 year parts and labour warranty. We'll even register them on your behalf so you don't have to worry about a thing. During your warranty period you are protected against the cost of parts, call-out and labour charges. All work is carried out by our national network of approved AEG engineers.



To find out more visit www.aeg.co.uk
or call **0800 479 0775**

ENERGY INFORMATION/ EU ENERGY EFFICIENCY INFORMATION

This scheme, which covers refrigerators, freezers, washing machines, tumble dryers, dishwashers and electric ovens is designed to offer consumers a standardised method of choosing the most energy efficient appliances.

For refrigerators and freezers, as well as stating the energy efficiency class (A+++ - most efficient, 'D' - least efficient) the label also gives the annual electricity consumption (i.e. running cost) freezing capacity, noise level and the usable storage capacity.

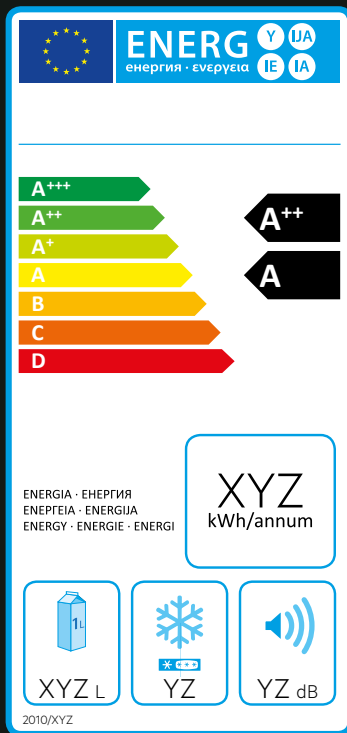

Example of refrigeration energy label.

For dishwashers, as well as stating the energy efficiency class (A+++ - most efficient, 'D' - least efficient) the label also states the annual water consumption (lts), drying efficiency, place settings and noise level.



Example of dishwasher energy label.

For washing machines, as well as stating the energy efficiency class (A+++ - most efficient, 'D' - least efficient) the label also states the annual water consumption (lts), load size (kg), spin speed efficiency and the washing & spinning noise levels.

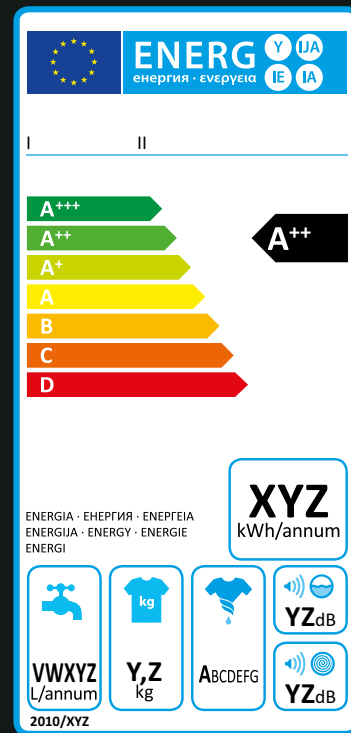

Example of washing machine energy label.

For electric ovens, as well as stating the energy efficiency ('A' - most efficient, 'G' - least efficient), the label also states the energy consumption (in kWh) and the usable volume of the oven. If the oven is a double oven it will carry this information for both ovens.

AFTER SALES SUPPORT/ CUSTOMER CARE

Customer Service

Should you need to contact us about your product we have a dedicated AEG customer service team to help. Our team is based in the AEG UK head office and can be contacted by phone on 03445 611 611 or via www.aeg.co.uk

Local service, nationwide

Our national network of Service Force agents provide product maintenance, genuine parts and repairs for all AEG Major Appliances. Genuine AEG parts ensure you continue to experience the excellent performance you expect from your AEG product.

If you require a visit from one of our agents for your Major Appliance please call our Service Force team on 03445 616 616.



AEG Major Appliances
Addington Way
Luton LU4 9QQ
Telephone: 03445 611 611

AEG Major Appliances is a
division of Electrolux plc.
Registered in England, No. 2331516.
Registered Office, Addington Way,
Luton LU4 9QQ

AEG Major Appliances
Electrolux Group Ireland Ltd
Suite 7 & 8 Westland House,
Westland Business Park,
Nangor Road,
Dublin 12 D12 TR98

Tel: 00353 (0)818 543000

Registered in Ireland No 9118.
Registered office:
Nangor Road,
Dublin 12 D12 TR98

Part number: 506005906009

Printed May 2018

AEG

Premier Partner

AEG has been creating pioneering appliances for the home for over 125 years. While others are catching up, we're moving further on, always an idea ahead. So if you want to know about true state-of-the-art technology, take a look inside.

To find out more visit aeg.co.uk